

**The Harman Kardon  
Model hk580i**

---

**Digital Synthesized Quartz-Locked  
Stereo Receiver**

**Technical Manual**

**harman/kardon**

## PRECAUTIONS

1. Always disconnect the chassis from power line when soldering. Turning the power switch OFF is not enough. Power line leakage passing through the heating element may destroy the transistors.
2. Never attempt to do any work on the transistor amplifiers without first disconnecting the AC line cord and waiting until the power supply filter capacitors have discharged.
3. Replacement for output and driver transistors, if necessary, must be made from the same beta group as the original type.
4. If one output transistor burns out (open or short) always remove all the output transistors in that channel and check the bias adjustment, the control and other parts in the network with an ohmmeter before inserting a new transistor. All transistors in one channel will be destroyed if the base biasing circuit is open on the emitter end.
5. When mounting a replacement power transistor, be sure that the bottom of the flange, the mica insulators and the surface of the heat sink are free of foreign matter, for they may cause transistor failure.
6. Silicon grease must be applied between the transistor and the mica insulator, and between the mica insulator and the heat sink for better heat conduction.
7. Fuses must be replaced with size and type indicated. Use of other types can expose components to destructive current levels.

## ALIGNMENT PROCEDURES

### AM ALIGNMENT

- Instruments:**
1. AM Signal Generator modulated with 400Hz at 30%.
  2. Oscilloscope
  3. AC V.T.V.M.
  4. DC Voltmeter

- Notes:**
1. Set function selector switch to AM position.
  2. Connect signal source to a loop placed to radiate signals into AM antenna loop stick (L252).

Step	Signal Source	Connect Output Meter To	Station Display Setting	Adjust	Adjust For
1	450kHz	VTVM and oscilloscope to TP1 and ground	1610kHz	T251, T252, T253	Maximum output on VTVM and at the same time clean wave form on oscilloscope
2	450kHz	VTVM and oscilloscope to TP2 and ground	1610kHz	T254	Same as above
3	—	DC voltmeter to TP3 and ground	530kHz	L251	1.6V on DC voltmeter
4	—	Same as above	1610kHz	TC251	22.5V on DC voltmeter
5	600kHz	VTVM to Tape 1 Out jack	600kHz	L252	Maximum output on VTVM
6	1400kHz	Same as above	1400kHz	TC252	Same as above
7	Repeat steps 5 and 6 for optimum sensitivity.				
8	1000kHz 40dB/m(100 $\mu$ V/m)	Oscilloscope to Tape 1 Out jack	1000kHz	VR251	Clean wave form on oscilloscope

## ALIGNMENT PROCEDURES

### FM ALIGNMENT

- Instruments:**
1. FM Signal Generator modulated with 1000Hz at 100% (75kHz).
  2. Oscilloscope
  3. Frequency Counter
  4. Distortion Meter
  5. AC V.T.V.M.
  6. DC Voltmeter

- Notes:**
1. Set function selector switch to FM position.
  2. Set muting switch to OFF (button in) position.
  3. Connect signal source to FM antenna terminals.

Step	Signal Source	Connect Output Meter To	Station Display Setting	Adjust	Adjust For
1	—	DC voltmeter to TP3 and ground	88.1MHz	Lo	3V on DC voltmeter
2	—	Same as above	107.9MHz	TC <sub>o</sub>	21V on DC voltmeter
3	90.1MHz 65dBf (970 $\mu$ V)	VTVM to Tape 1 Out jack	90.1MHz	L <sub>A</sub> , L <sub>R1</sub> , L <sub>R2</sub>	Maximum output on VTVM
4	106.1MHz 65dBf (970 $\mu$ V)	Same as above	106.1MHz	TC <sub>A</sub> , TC <sub>R1</sub> , TC <sub>R2</sub>	Same as above
5	Repeat steps 3 and 4 for optimum sensitivity.				
6	—	Frequency counter to TP4 and ground	98.3MHz	TC801	109MHz on frequency counter
7	Set Muting switch to ON position.				
8	98.15MHz 65dBf (970 $\mu$ V)	Oscilloscope to Tape 1 Out jack	98.1MHz	T201(A)	Clean wave on oscilloscope
9	98.05MHz 65dBf (970 $\mu$ V)	Same as above	98.1MHz	T202(A)	Same as above
10	Repeat steps 8 and 9 for optimum sensitivity.				
11	98.1MHz 65dBf (970 $\mu$ V)	Distortion meter to Tape 1 Out jack	98.1MHz	T201(B)	Minimum reading on distortion meter
12	Repeat steps 8, 9 and 11 for optimum alignment point of T201(A) and (B).				

### QUARTZ LOCK INDICATOR ADJUSTMENT

**Instrument:** FM Signal Generator modulated with 1000Hz at 100% (75kHz).

- Notes:**
1. Set function selector switch to FM position.
  2. Set muting switch to OFF (button in) position.
  3. Connect signal source to FM antenna terminals.
  4. Turn the VR351 to the center.

Signal Source	Station Display Setting	Adjust	Adjust For
98.1MHz 13dBf (2.4 $\mu$ V)	98.1MHz	VR201	Quartz indicator LED lights

## ALIGNMENT PROCEDURES

### SIGNAL STRENGTH DISPLAY ADJUSTMENT

- Instruments:**
1. AM Signal Generator modulated with 400Hz at 30%.
  2. FM Signal Generator modulated with 1000Hz at 100% (75kHz).
  3. DC Voltmeter

- Notes:**
1. Set muting switch to OFF (button in) position.
  2. Set tuning switch to MANUAL position.
  3. Turn the mute adjust control (rear panel) fully counterclockwise.
  4. Turn the VR354 and VR351 to center.

Step	Connect Signal Source To	Set Signal Generator To	Connect Output Meter To	Station Display Setting	Adjust	Adjust For
1	Set Function selector switch to AM position.					
2	Place loop to radiate signals into AM antenna loop stick (L252).	1000kHz 74dB/m (2.8mV/m)	DC voltmeter to TP5 and ground	1000kHz	VR354	8V on DC voltmeter
3	Set Function selector switch to FM position.					
4	Place generator leads across FM antenna terminals.	98.1MHz 65dBf (970 $\mu$ V)	DC voltmeter to TP5 and ground	98.1MHz	VR351	9V on DC voltmeter

### MPX ADJUSTMENT

- Instruments:**
1. FM Signal Generator modulated with 1000Hz at 100% (75kHz).
  2. Frequency Counter

- Notes:**
1. Set function selector switch to AUTO FM position.
  2. Connect signal source to FM antenna terminals.

Signal Source	Connect Output Meter To	Station Display Setting	Adjust	Adjust For
98.1MHz 65dBf (970 $\mu$ V)	Frequency Counter to TP6 and ground	98.1MHz	VR302	76kHz on frequency counter

### STEREO FM INDICATOR ADJUSTMENT

- Instrument:** FM Stereo Signal Generator modulated with 1000Hz at 100% (75kHz).  
(L + R = 45% L - R = 45% 19kHz = 9%)

- Notes:**
1. Set function selector switch to AUTO FM position.
  2. Connect signal source to FM antenna terminals.

Signal Source	Station Display Setting	Adjust	Adjust For
98.1MHz 36dBf (30 $\mu$ V)	98.1MHz	VR352	Stereo FM indicator LED lights

## ALIGNMENT PROCEDURES

### SEPARATION ADJUSTMENT

**Instruments:** 1. FM Stereo Signal Generator modulated with 1000Hz at 100% (75kHz).  
(L+R=45% L-R=45% 19kHz=9%)  
2. AC V.T.V.M.

**Notes:** 1. Set function selector switch to AUTO FM position.  
2. Set blend control to STEREO position.  
3. Connect signal source to FM antenna terminals.

Step	Signal Source	Connect Output Meter To	Station Display Setting	Adjust	Adjust For
1	Set Lch signal ON at FM stereo signal generator.				
2	98.1MHz 65dBf (970 $\mu$ V)	VTVM to Rch Tape 1 Out jack	98.1MHz	VR301, VR321	Minimum output on VTVM
3	Set Rch signal ON at FM stereo signal generator.				
4	98.1MHz 65dBf (970 $\mu$ V)	VTVM to Lch Tape 1 Out jack	98.1MHz	VR301, VR321	Minimum output on VTVM
5	Repeat steps 2 and 4 to obtain same level at left and right channels.				

### IDLING CURRENT ADJUSTMENT

**Instrument:** DC Voltmeter

**Notes:** 1. Set function selector switch to AUX position.  
2. Set volume control to minimum position.

Step	Connect Output Meter To	Adjust	Adjust For
1	DC voltmeter to TP7 (+) and TP8 (-)	VR404	33mV on DC voltmeter
2	DC voltmeter to TP9 (+) and TP10 (-)	VR403	Same as above

### DC VOLTAGE BALANCE ADJUSTMENT

**Instrument:** DC Voltmeter

**Notes:** 1. Set function selector switch to AUX position.  
2. Set volume control to minimum position.  
3. Press in speakers 1 push button to ON (button in) position.

Step	Connect Output Meter To	Adjust	Adjust For
1	DC voltmeter to Lch terminal of Speaker System 1	VR402	0V $\pm$ 50mV on DC voltmeter
2	DC voltmeter to Rch terminal of Speaker System 1	VR401	Same as above

## ALIGNMENT PROCEDURES

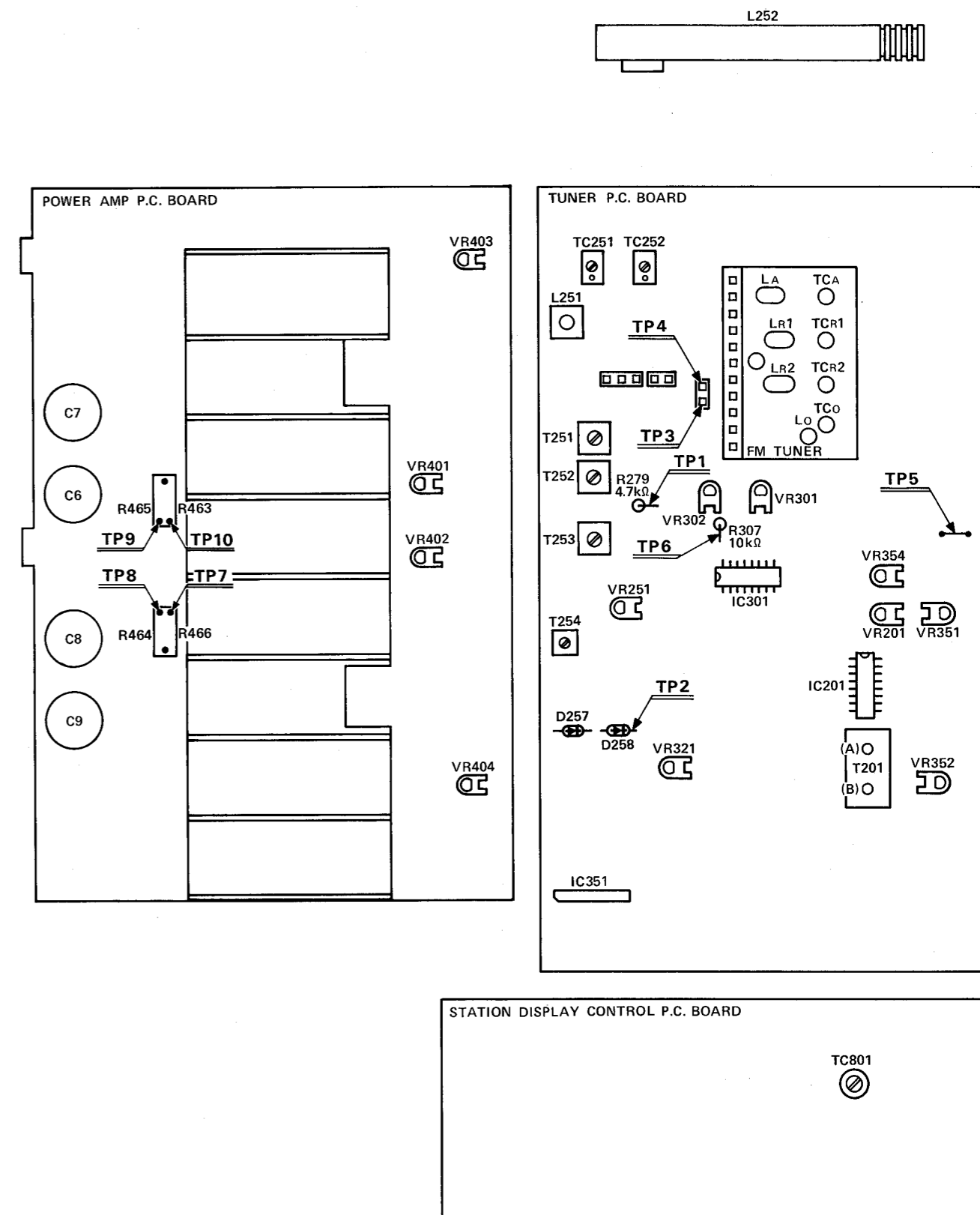

Fig. 1—Alignment Points Location

## ALIGNMENT PROCEDURES

### SEPARATION ADJUSTMENT

**Instruments:** 1. FM Stereo Signal Generator modulated with 1000Hz at 100% (75kHz).  
(L+R=45% L-R=45% 19kHz=9%)

2. AC V.T.V.M.

- Notes:** 1. Set function selector switch to AUTO FM position.  
2. Set blend control to STEREO position.  
3. Connect signal source to FM antenna terminals.

Step	Signal Source	Connect Output Meter To	Station Display Setting	Adjust	Adjust For
1	Set Lch signal ON at FM stereo signal generator.				
2	98.1MHz 65dBf (970 $\mu$ V)	VTVM to Rch Tape 1 Out jack	98.1MHz	VR301, VR321	Minimum output on VTVM
3	Set Rch signal ON at FM stereo signal generator.				
4	98.1MHz 65dBf (970 $\mu$ V)	VTVM to Lch Tape 1 Out jack	98.1MHz	VR301, VR321	Minimum output on VTVM
5	Repeat steps 2 and 4 to obtain same level at left and right channels.				

### IDLING CURRENT ADJUSTMENT

**Instrument:** DC Voltmeter

- Notes:** 1. Set function selector switch to AUX position.  
2. Set volume control to minimum position.

Step	Connect Output Meter To	Adjust	Adjust For
1	DC voltmeter to TP7 (+) and TP8 (-)	VR404	33mV on DC voltmeter
2	DC voltmeter to TP9 (+) and TP10 (-)	VR403	Same as above

### DC VOLTAGE BALANCE ADJUSTMENT

**Instrument:** DC Voltmeter

- Notes:** 1. Set function selector switch to AUX position.  
2. Set volume control to minimum position.  
3. Press in speakers 1 push button to ON (button in) position.

Step	Connect Output Meter To	Adjust	Adjust For
1	DC voltmeter to Lch terminal of Speaker System 1	VR402	0V $\pm$ 50mV on DC voltmeter
2	DC voltmeter to Rch terminal of Speaker System 1	VR401	Same as above

# ALIGNMENT PROCEDURES

ut on

ut on

ter

meter

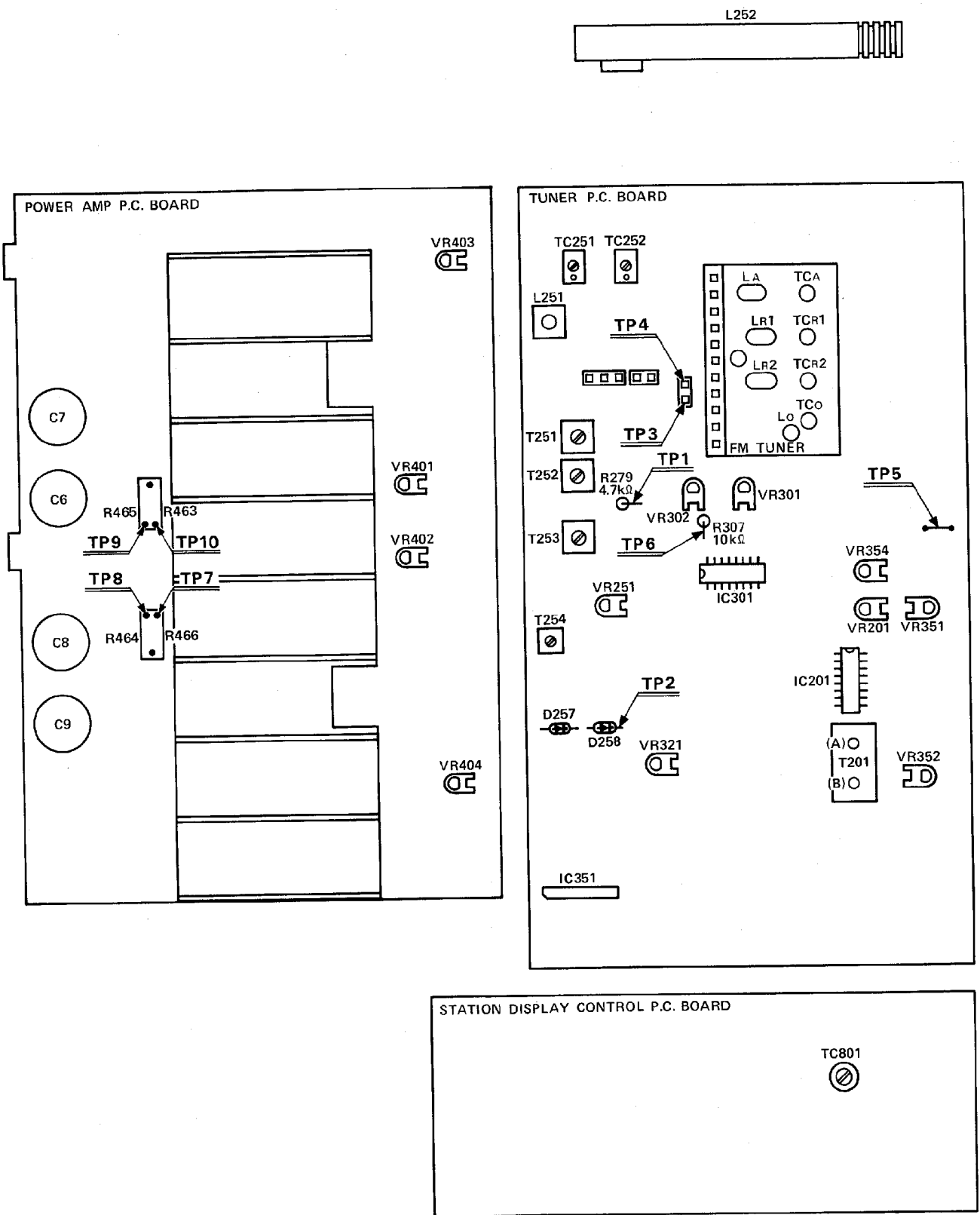
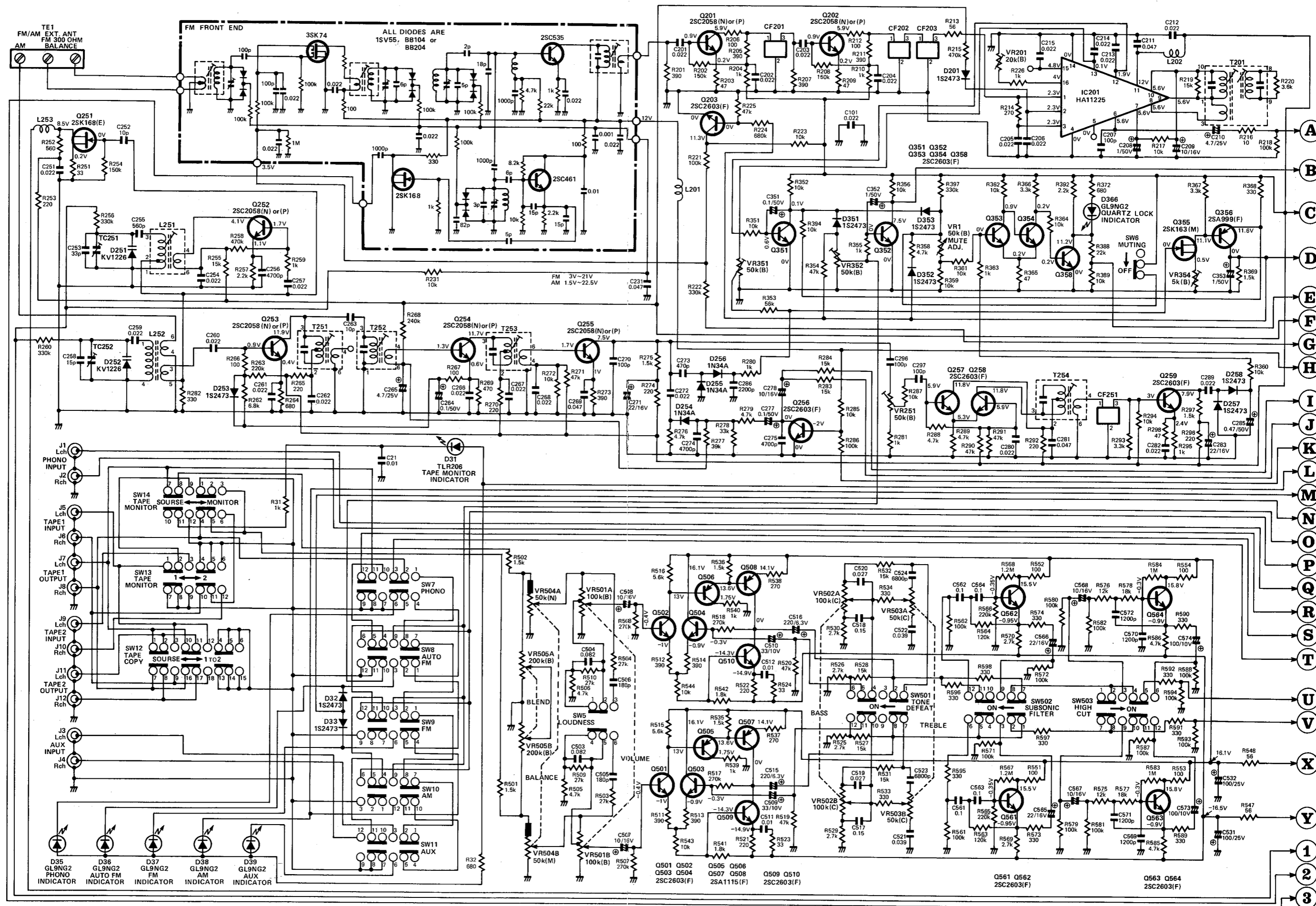

Fig. 1—Alignment Points Location

**SCHEMATIC DIAGRAM**





# SCHEMATIC DIAGRAM

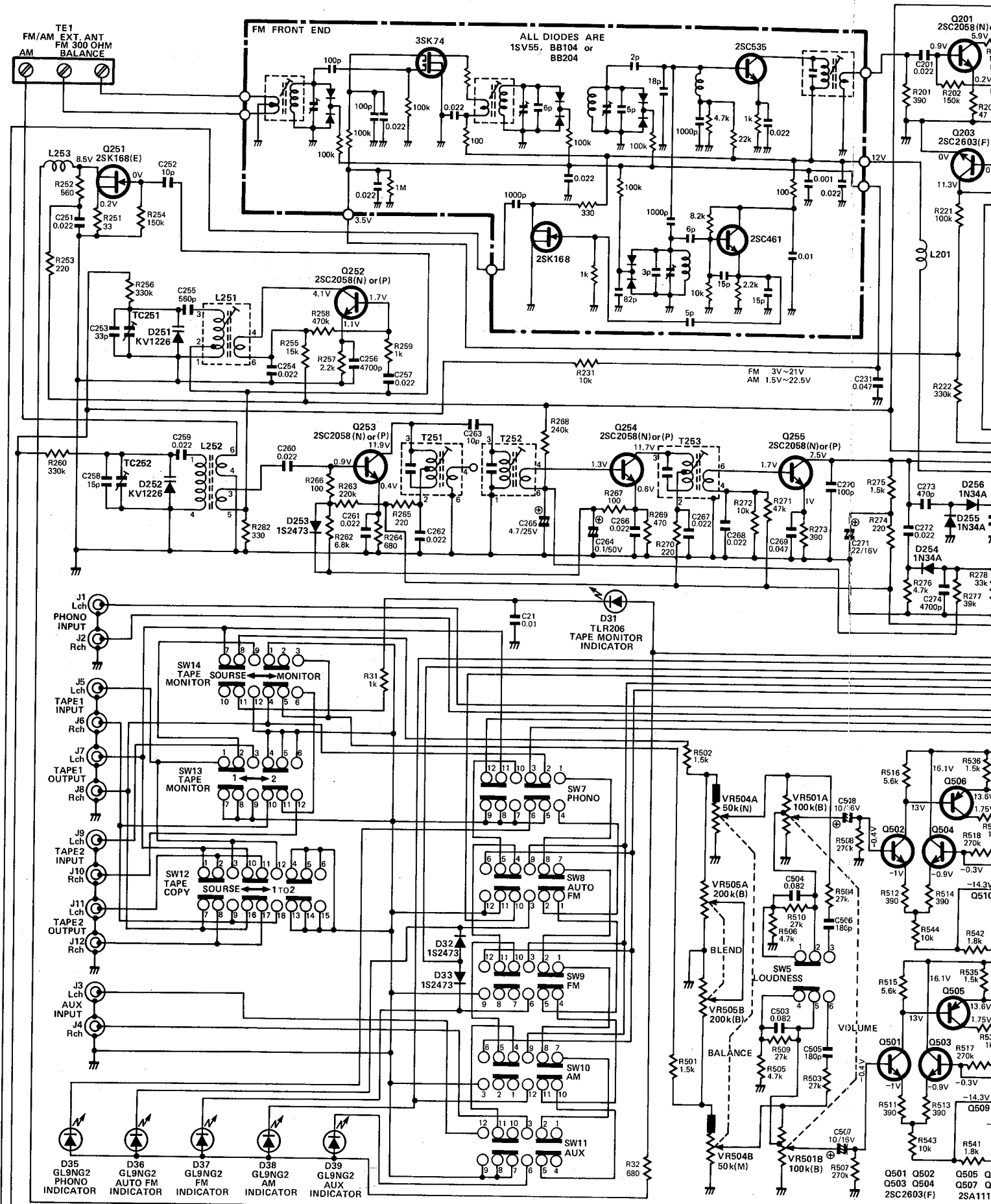

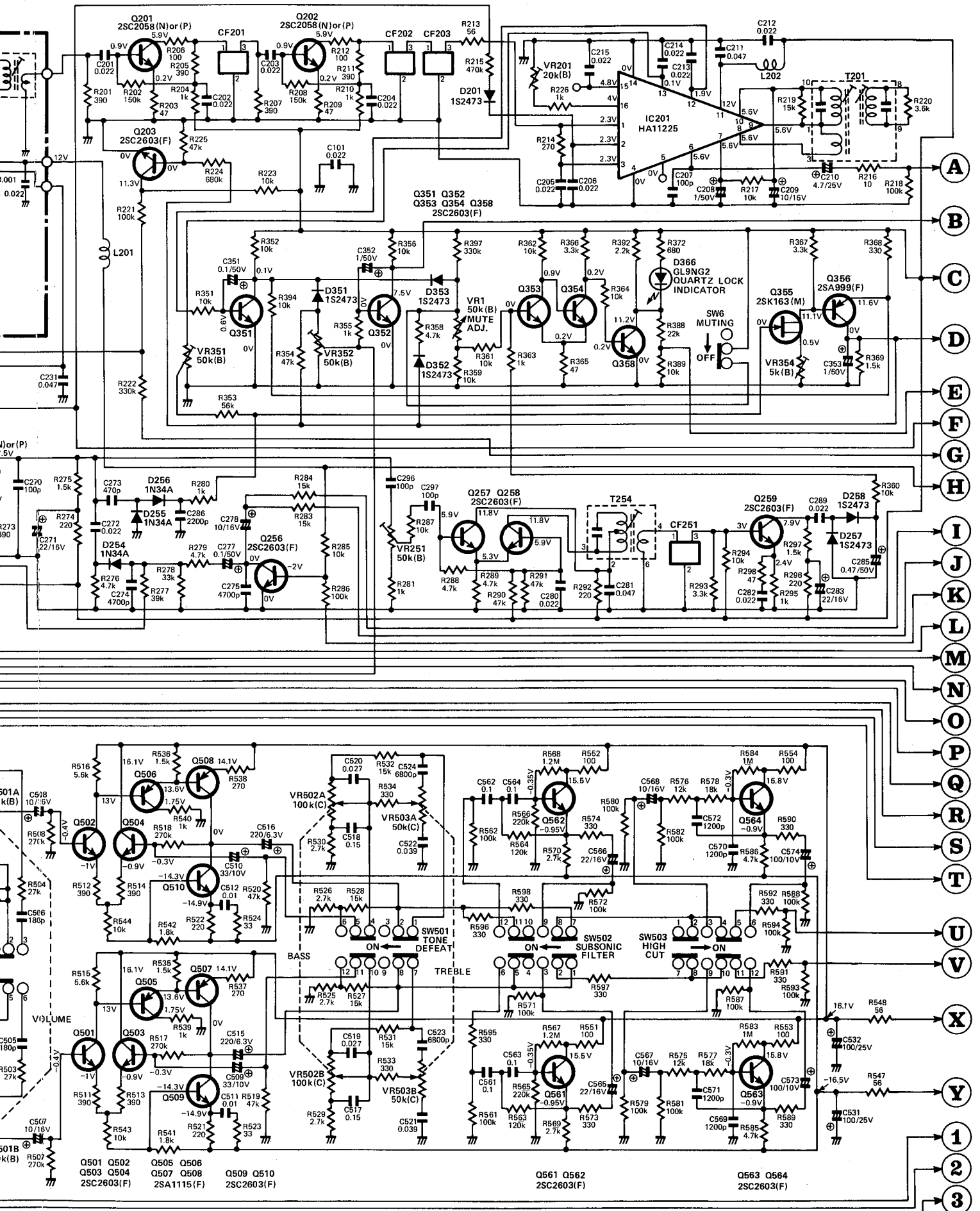

**SCHEMATIC DIAGRAM**

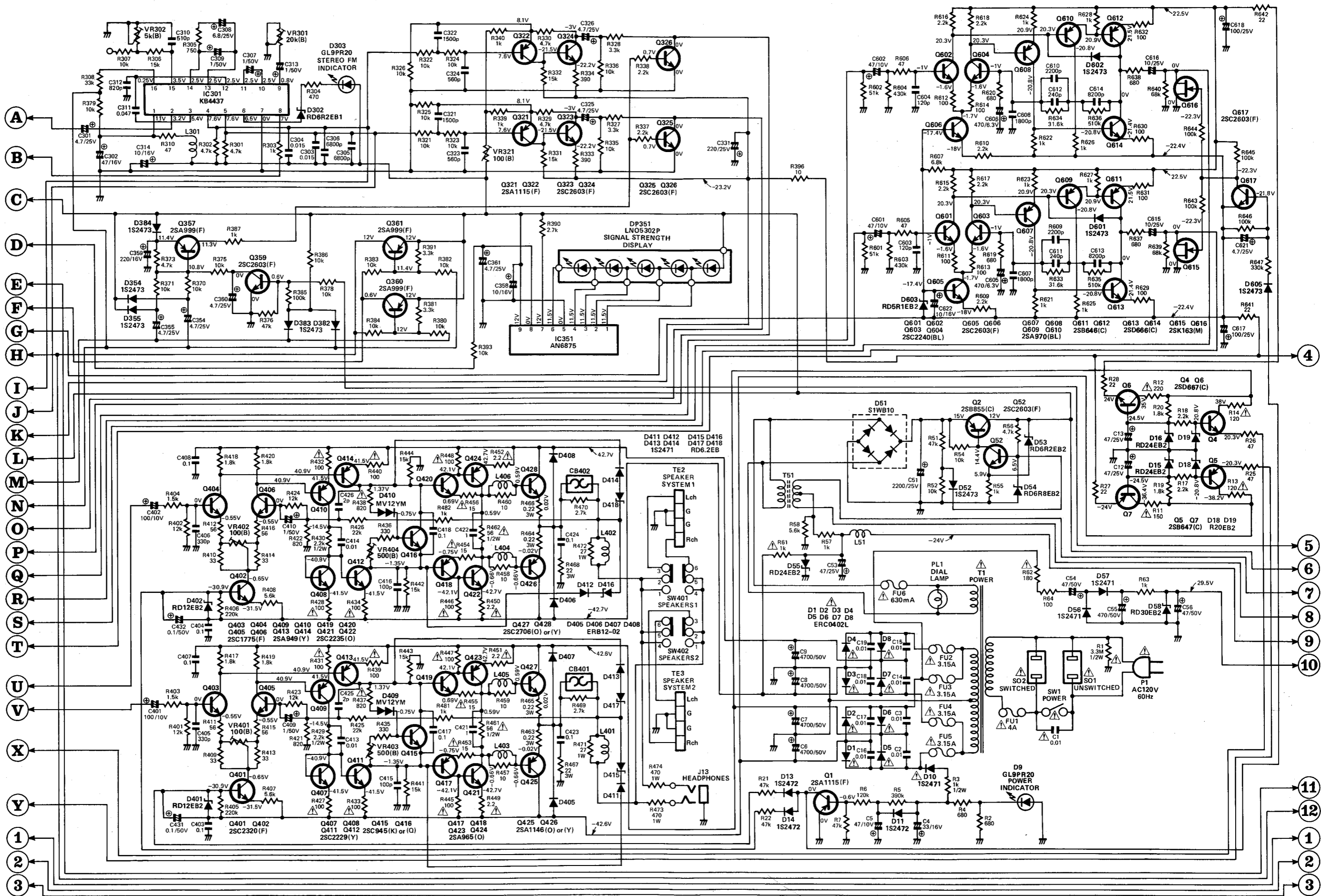

# SCHEMATIC DIAGRAM

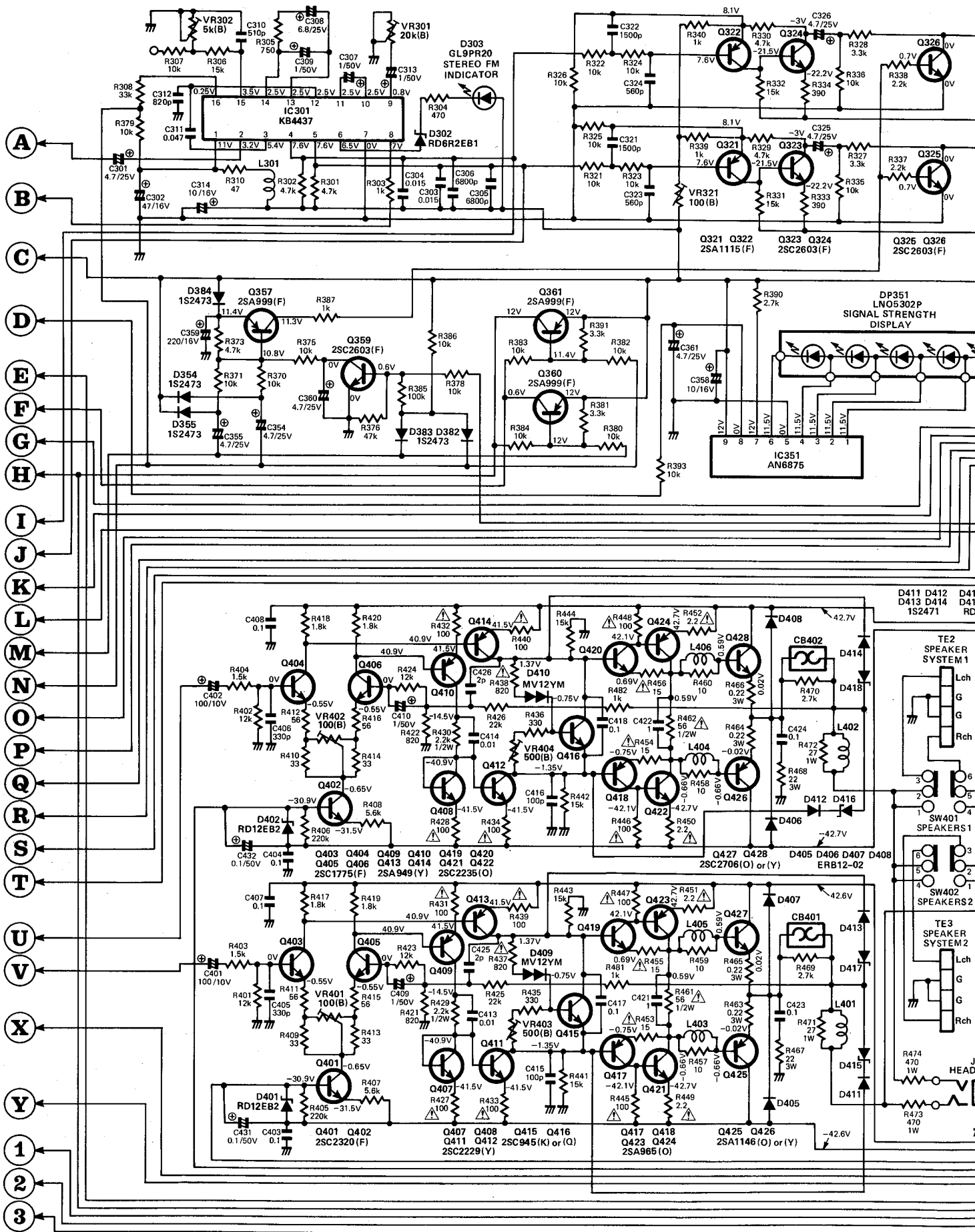

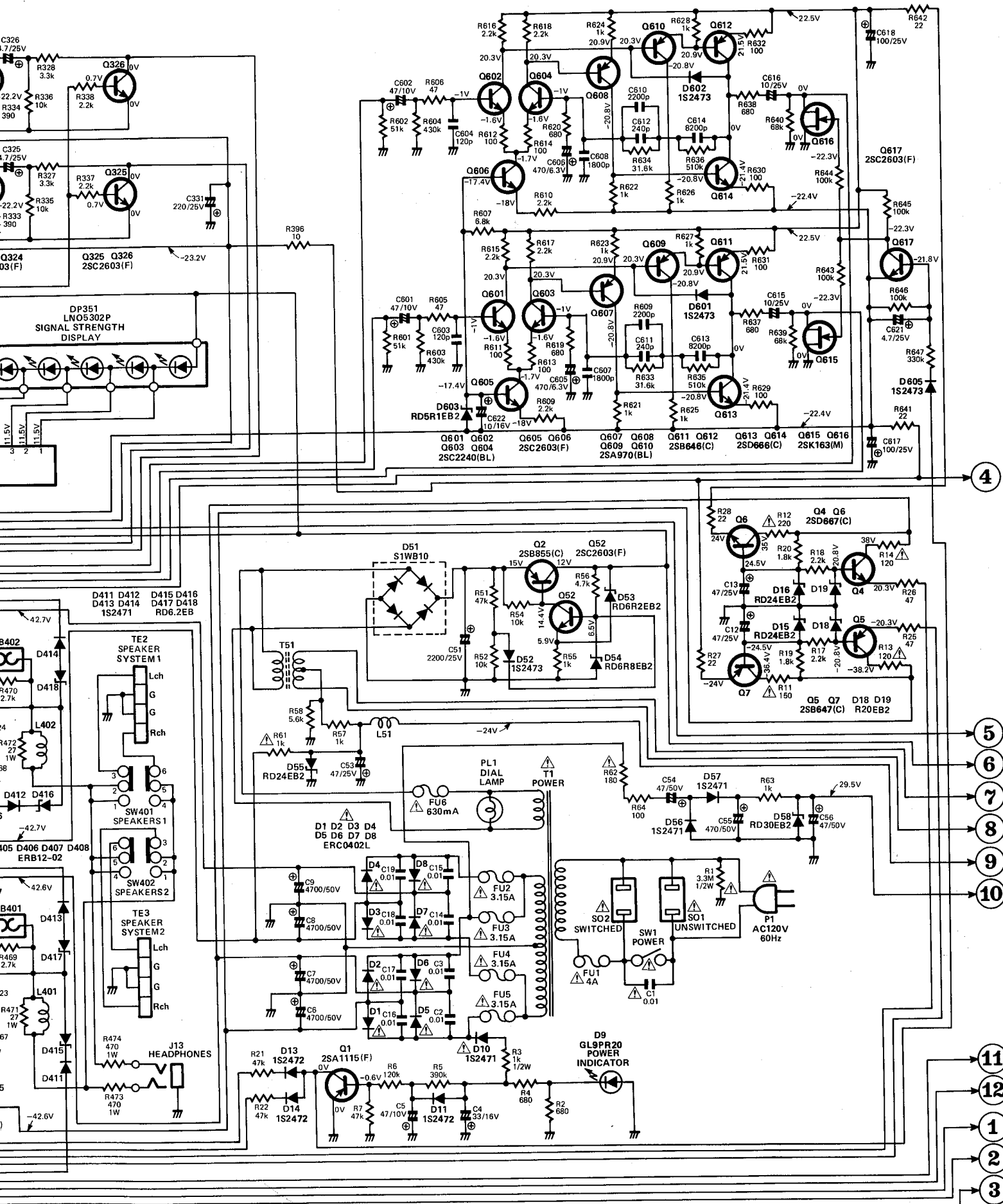

**SCHEMATIC DIAGRAM**

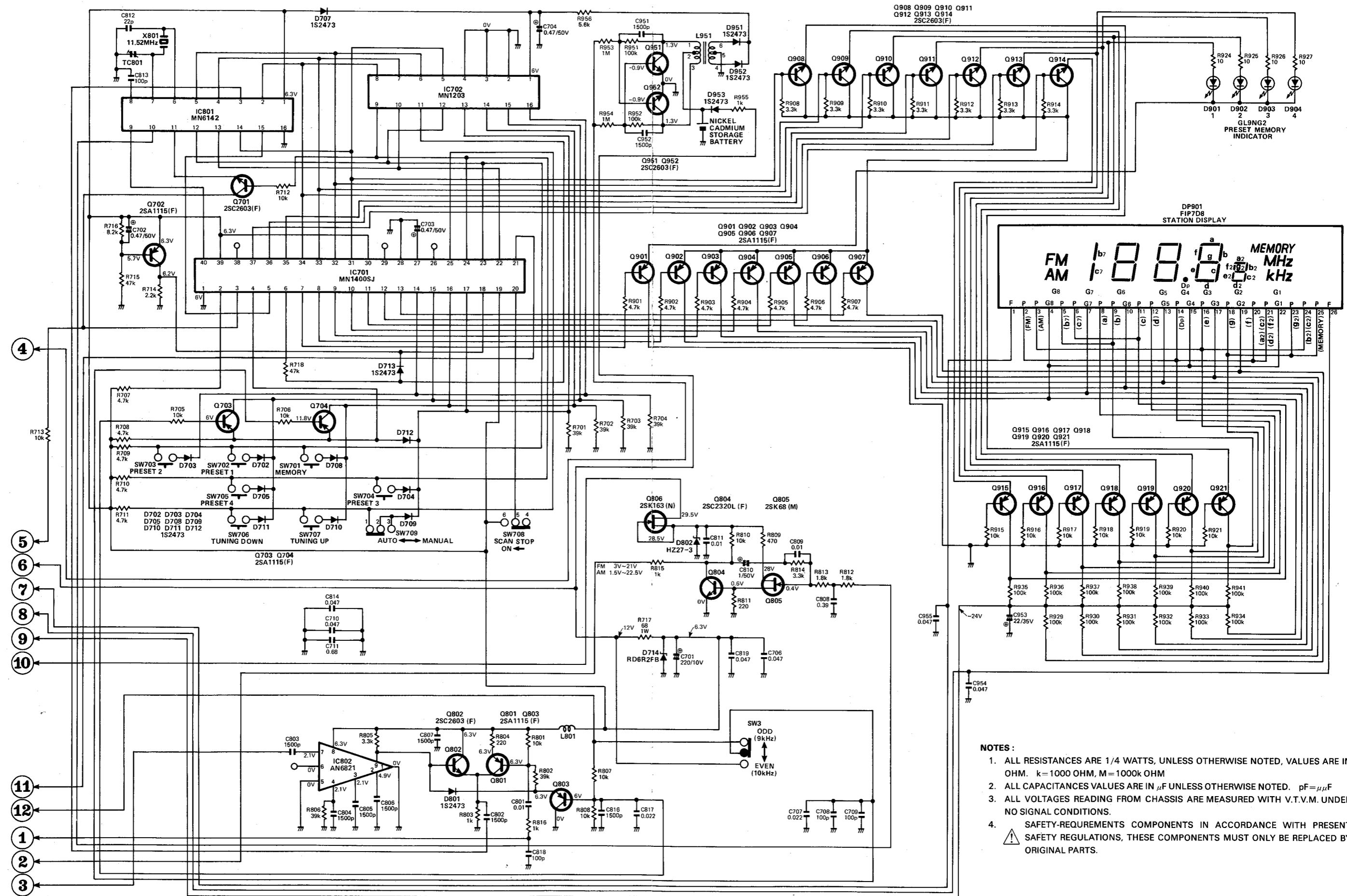

**NOTES:**

1. ALL RESISTANCES ARE 1/4 WATTS, UNLESS OTHERWISE NOTED, VALUES ARE IN OHM. k=1000 OHM, M=1000k OHM
2. ALL CAPACITANCES VALUES ARE IN  $\mu\text{F}$  UNLESS OTHERWISE NOTED. pF= $\mu\mu\text{F}$
3. ALL VOLTAGES READING FROM CHASSIS ARE MEASURED WITH V.T.V.M. UNDER NO SIGNAL CONDITIONS.
4. SAFETY-REQUIREMENTS COMPONENTS IN ACCORDANCE WITH PRESENT SAFETY REGULATIONS, THESE COMPONENTS MUST ONLY BE REPLACED BY ORIGINAL PARTS.

# SCHEMATIC DIAGRAM

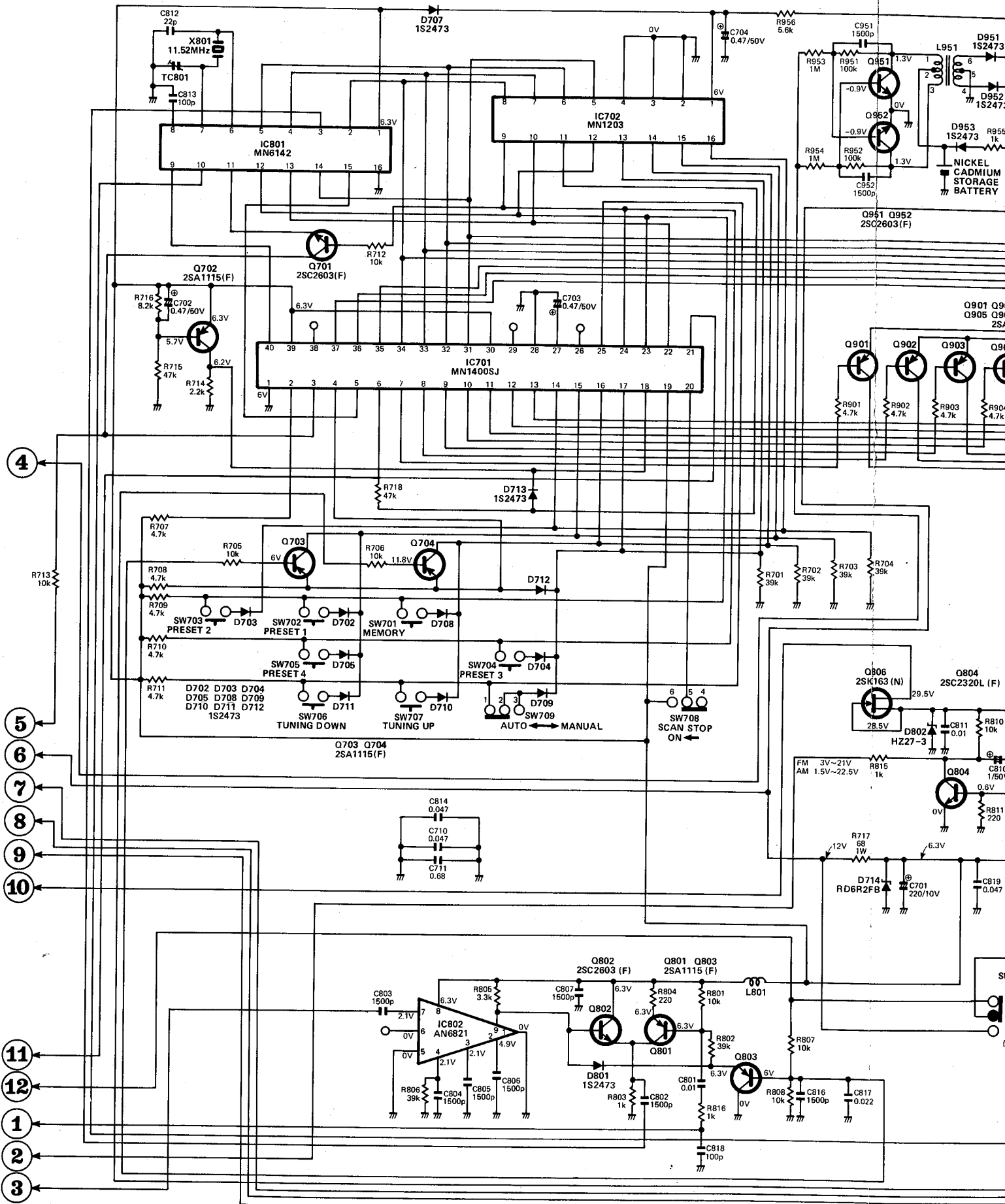

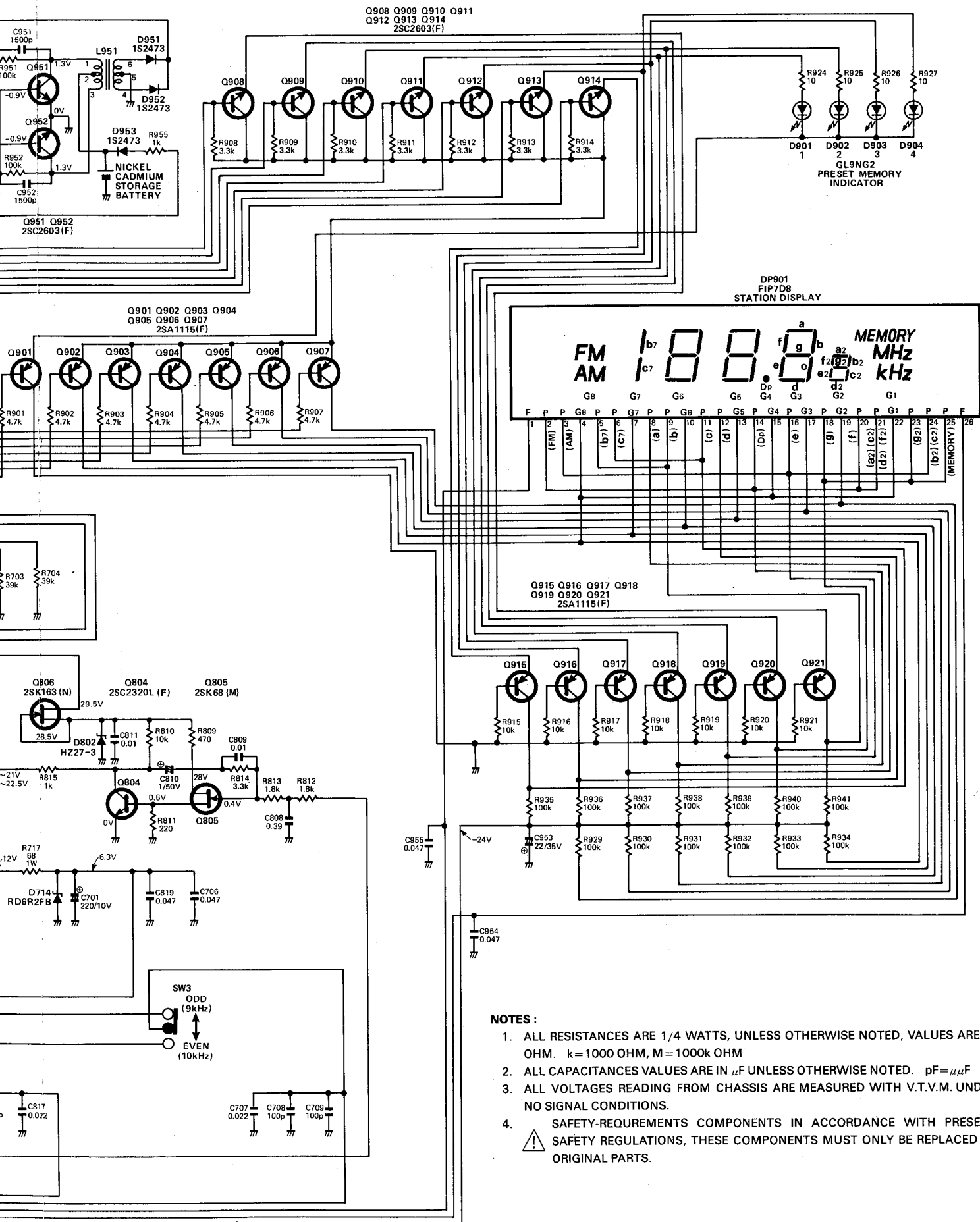

**NOTES :**

1. ALL RESISTANCES ARE 1/4 WATTS, UNLESS OTHERWISE NOTED, VALUES ARE IN OHM. k=1000 OHM, M=1000k OHM
2. ALL CAPACITANCES VALUES ARE IN  $\mu$ F UNLESS OTHERWISE NOTED. pF= $\mu$  $\mu$ F
3. ALL VOLTAGES READING FROM CHASSIS ARE MEASURED WITH V.T.V.M. UNDER NO SIGNAL CONDITIONS.
4. SAFETY-REQUIREMENTS COMPONENTS IN ACCORDANCE WITH PRESENT SAFETY REGULATIONS, THESE COMPONENTS MUST ONLY BE REPLACED BY ORIGINAL PARTS.



**SCHEMATIC DIAGRAM**

THE FOLLOWING SCHEMATIC DIAGRAM IS APPLIED TO MULTI VOLTAGE UNIT.

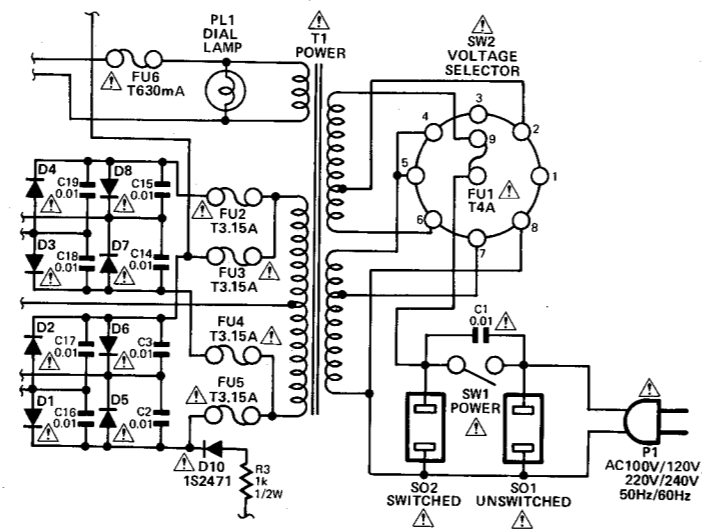
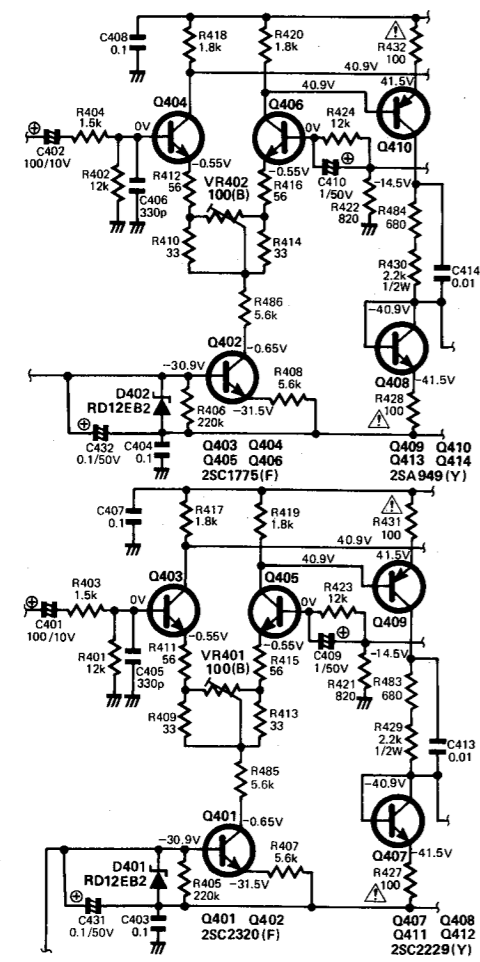
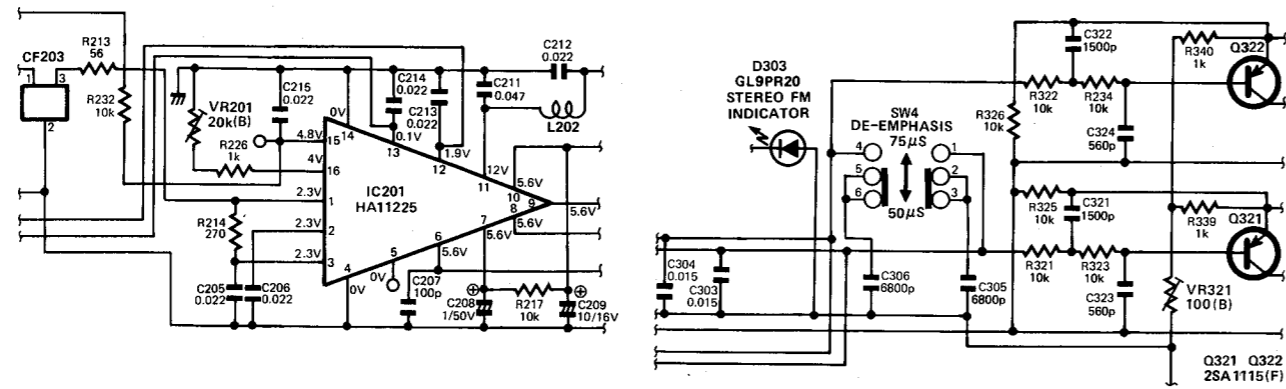

FOR EUROPE AND OCEANIA ONLY

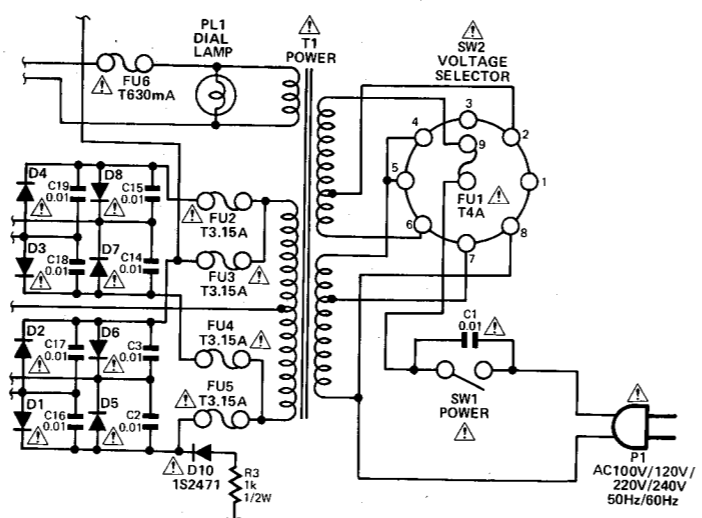

**TIME/SEQUENCE CHART**

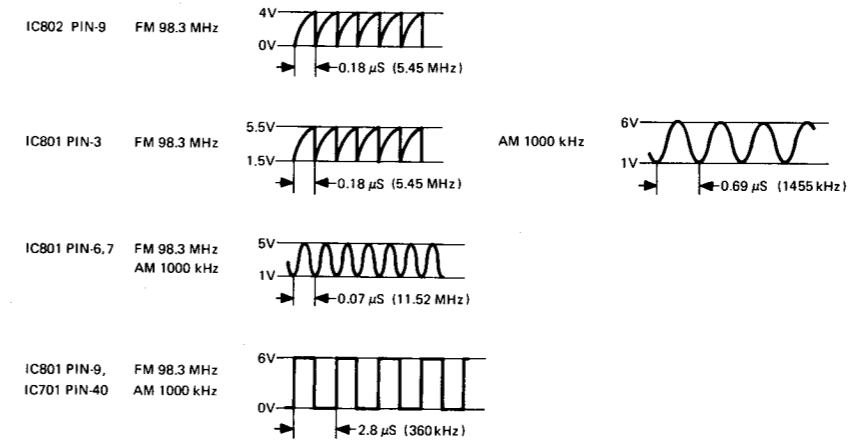

AM 1000 kHz SIGNAL RECEIVED AT MEMORY 2

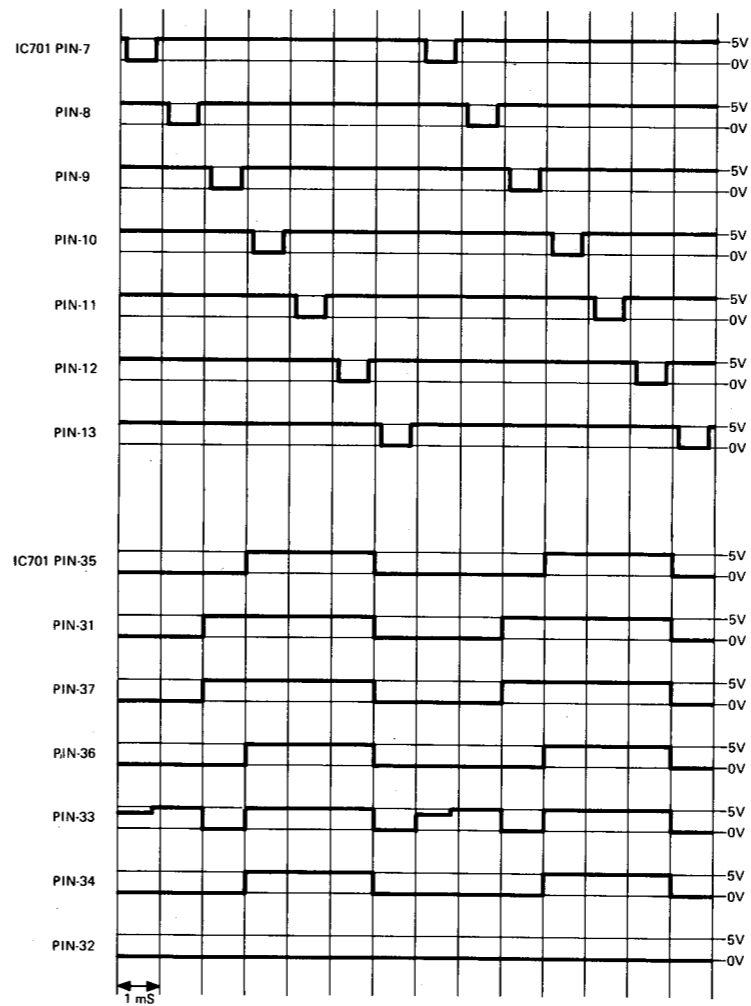

FM 98.3 MHz SIGNAL RECEIVED AT MEMORY 1

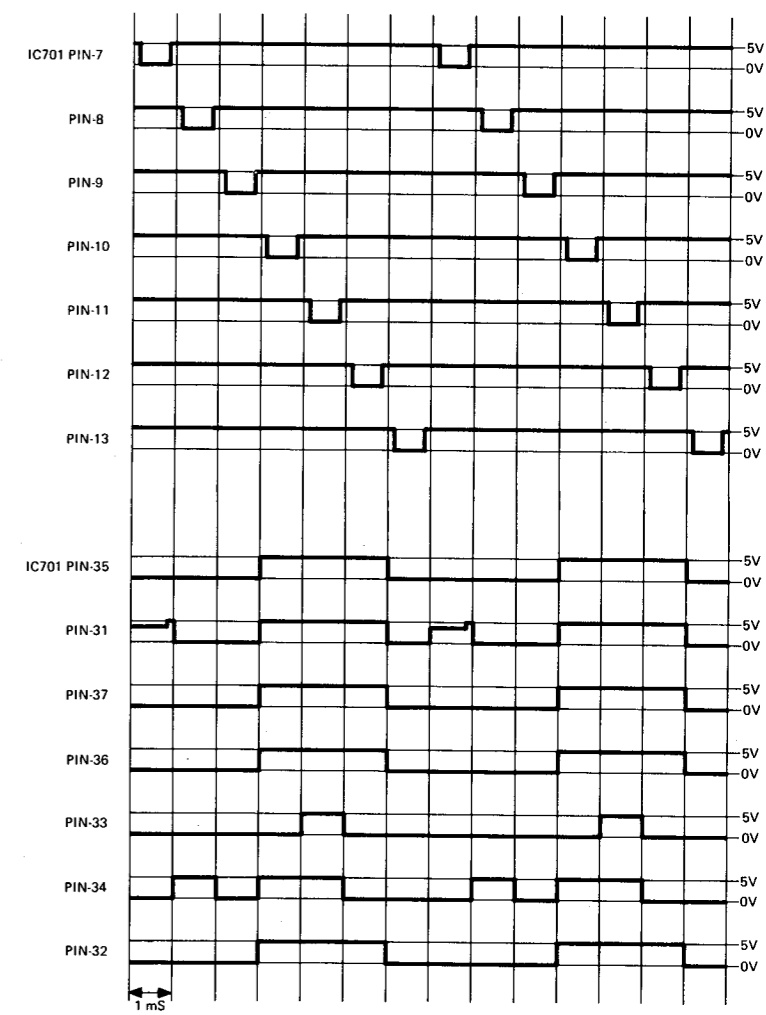

NOTE: The output signal from terminal number 7 in IC701 is applied to the oscillator trigger input.

# SCHEMATIC DIAGRAM

THE FOLLOWING SCHEMATIC DIAGRAM IS APPLIED TO MULTI VOLTAGE UNIT.

TIME/

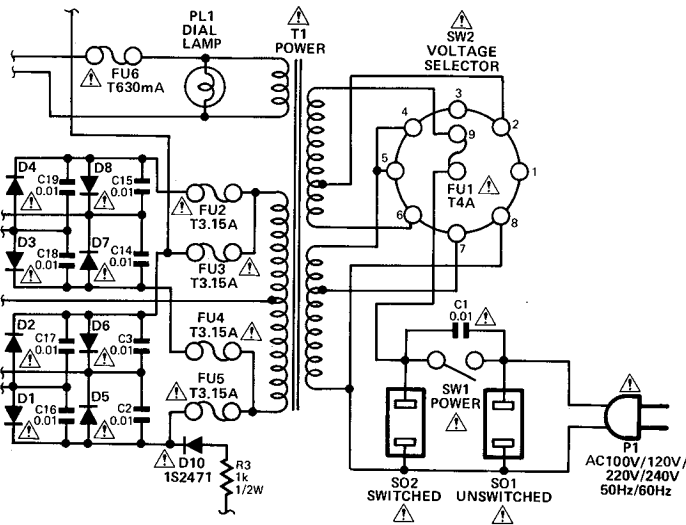
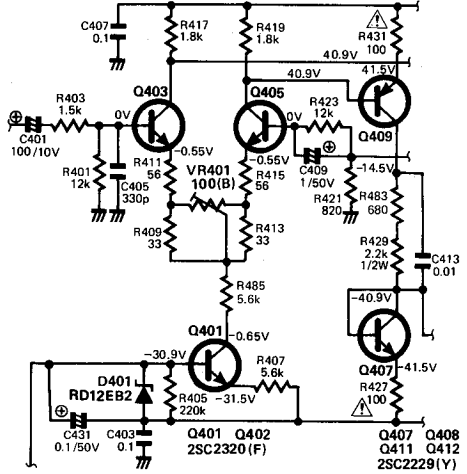
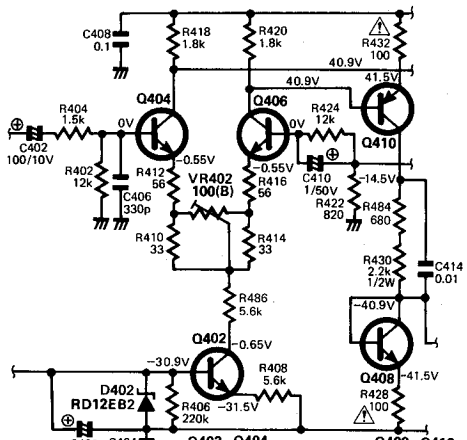
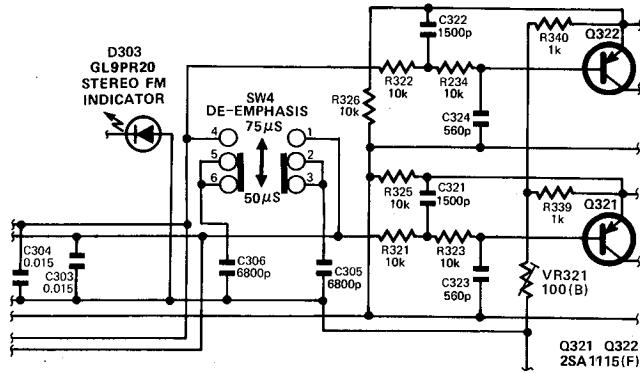
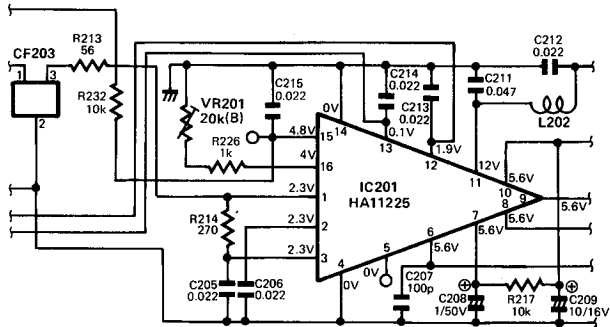

FOR EUROPE AND OCEANIA ONLY

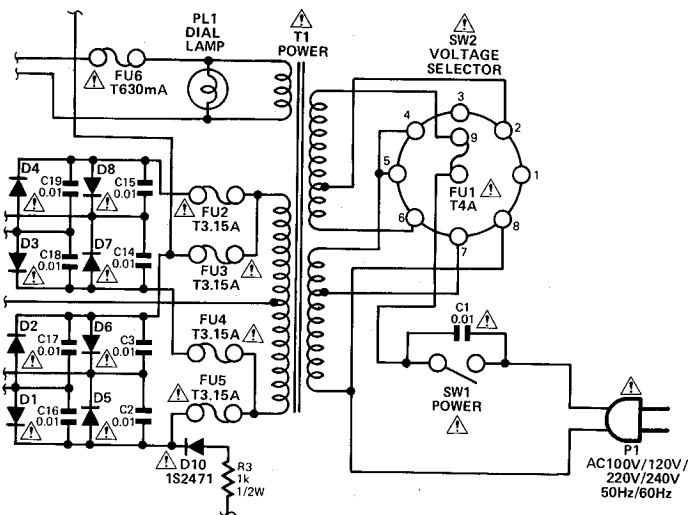

AM 1000

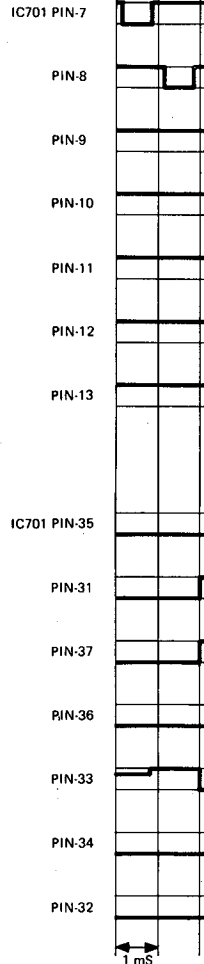

# TIME/SEQUENCE CHART

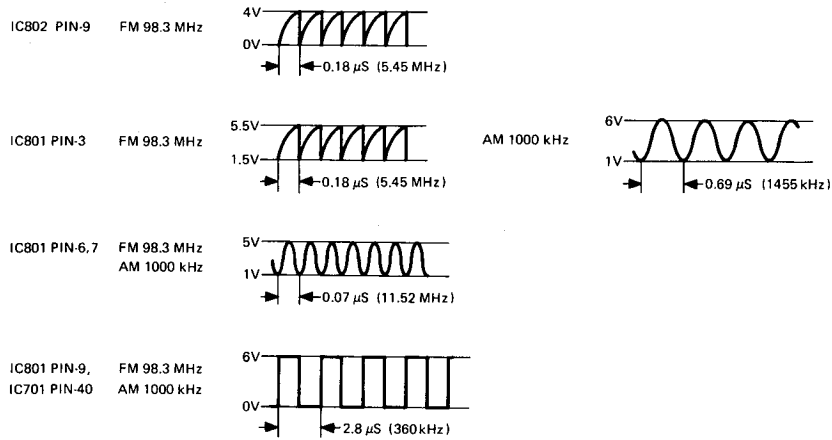

AM 1000 kHz SIGNAL RECEIVED AT MEMORY 2

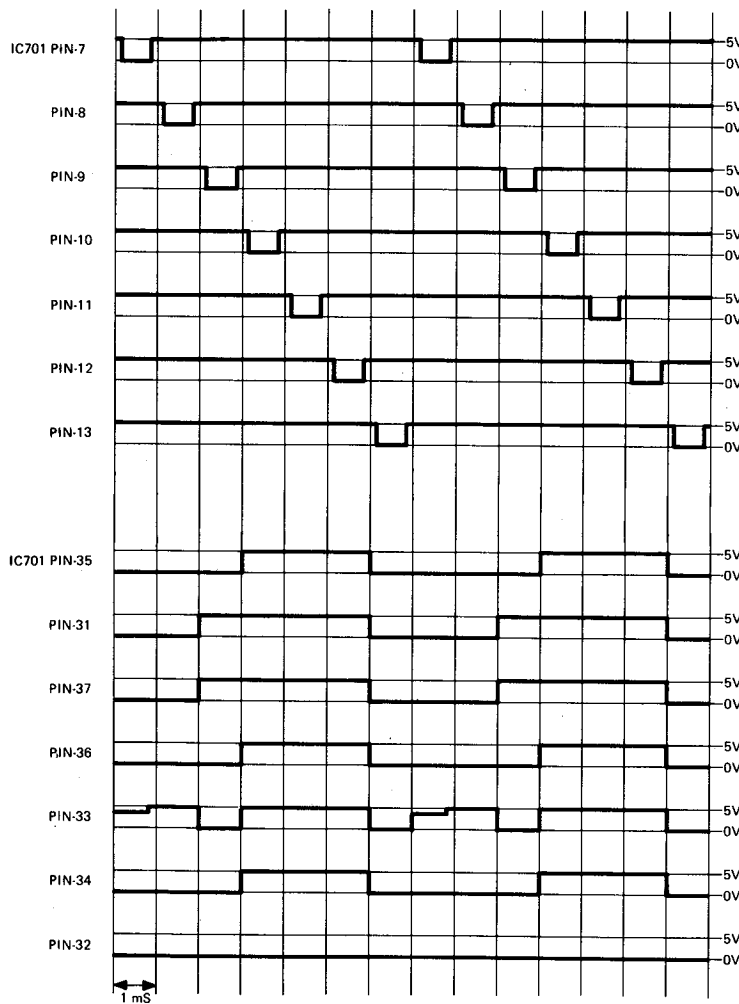

FM 98.3 MHz SIGNAL RECEIVED AT MEMORY 1

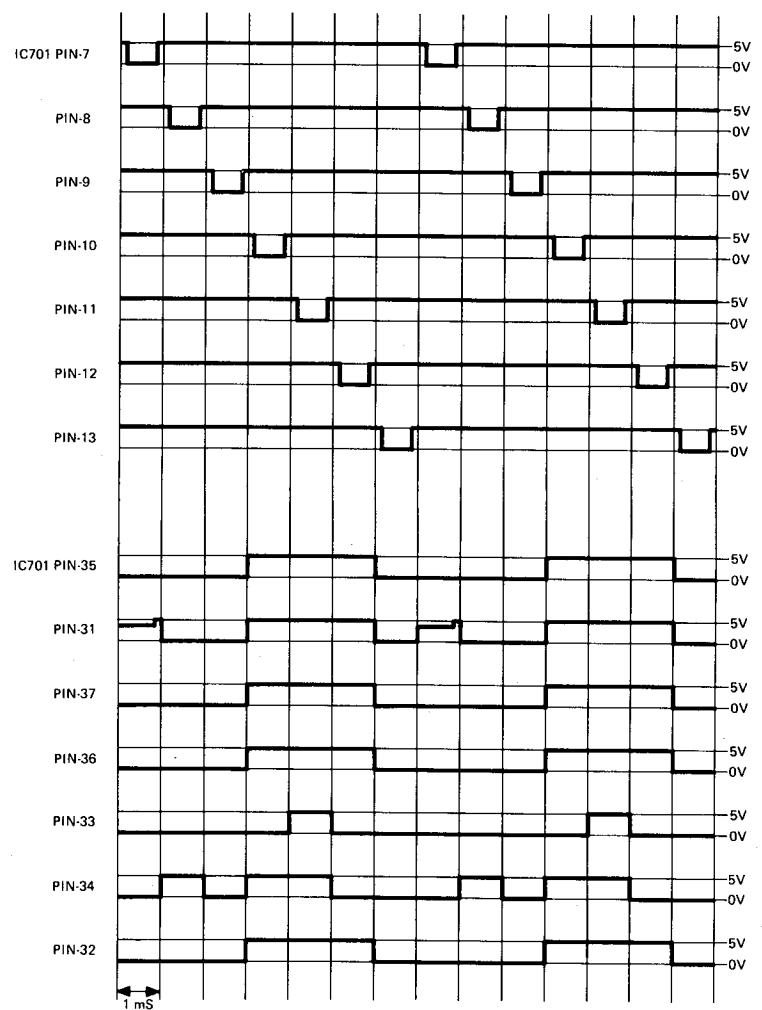

NOTE: The output signal from terminal number 7 in IC701 is applied to the oscillator trigger input.

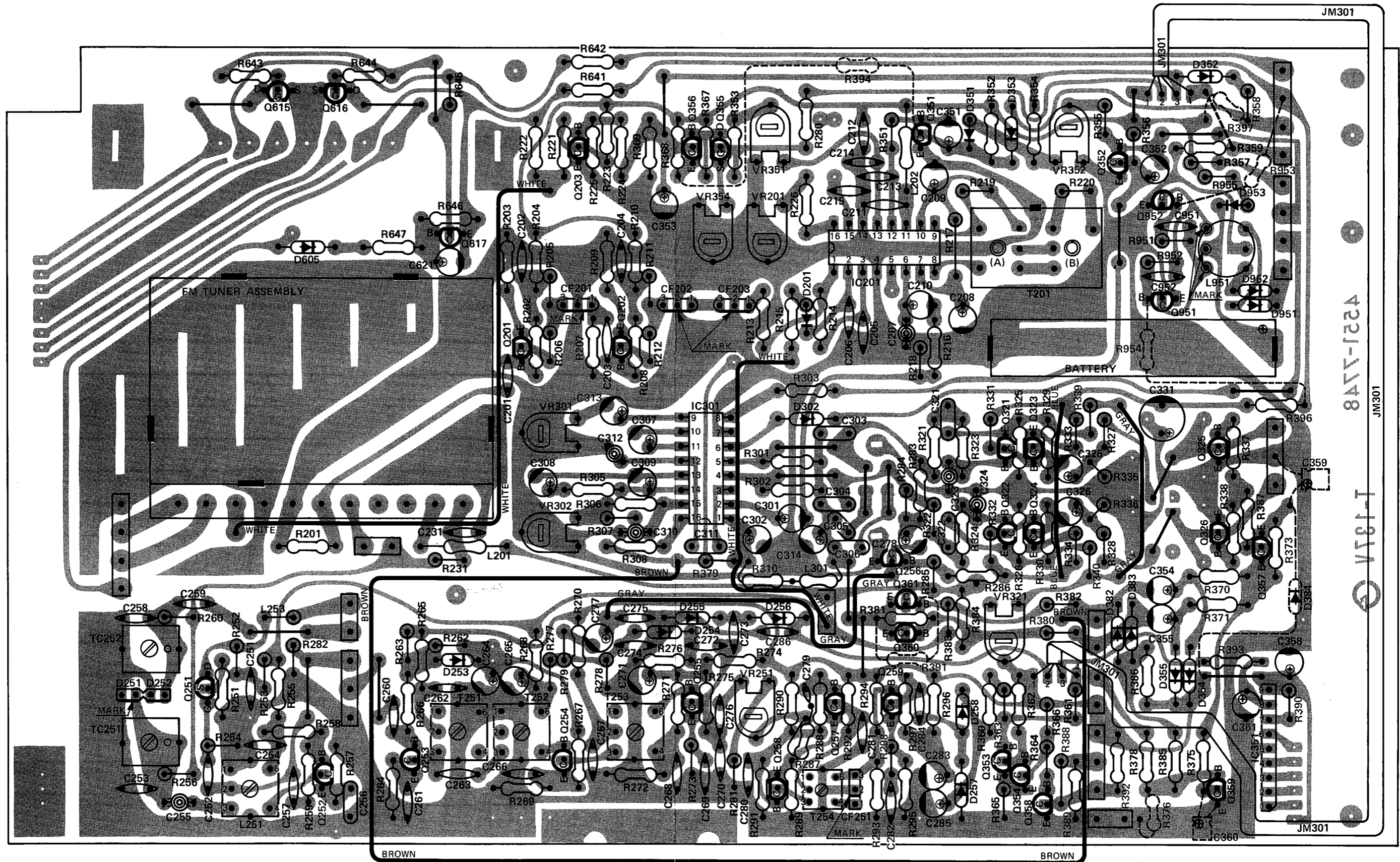

TUNER P.C.BOARD

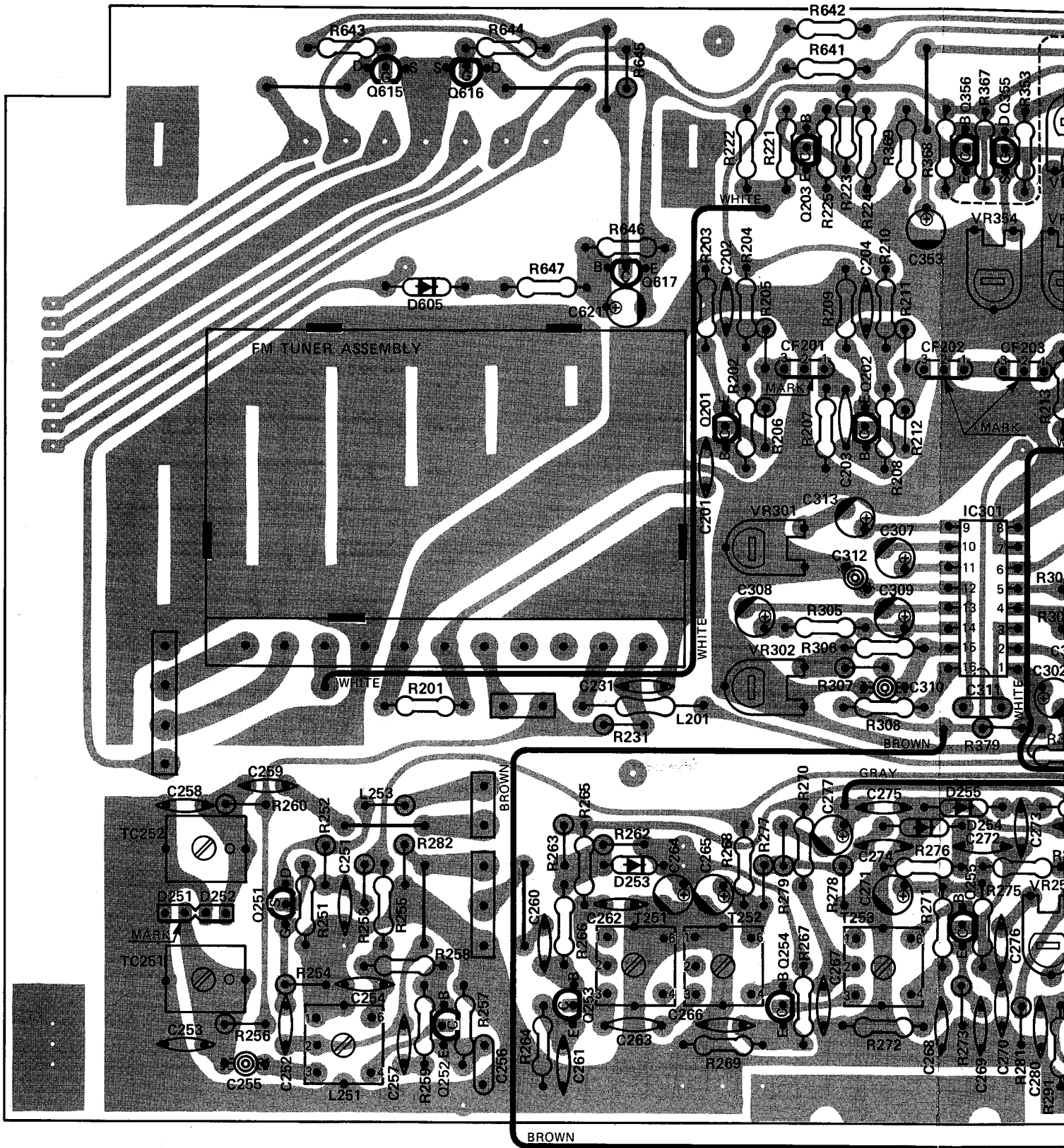

JM301

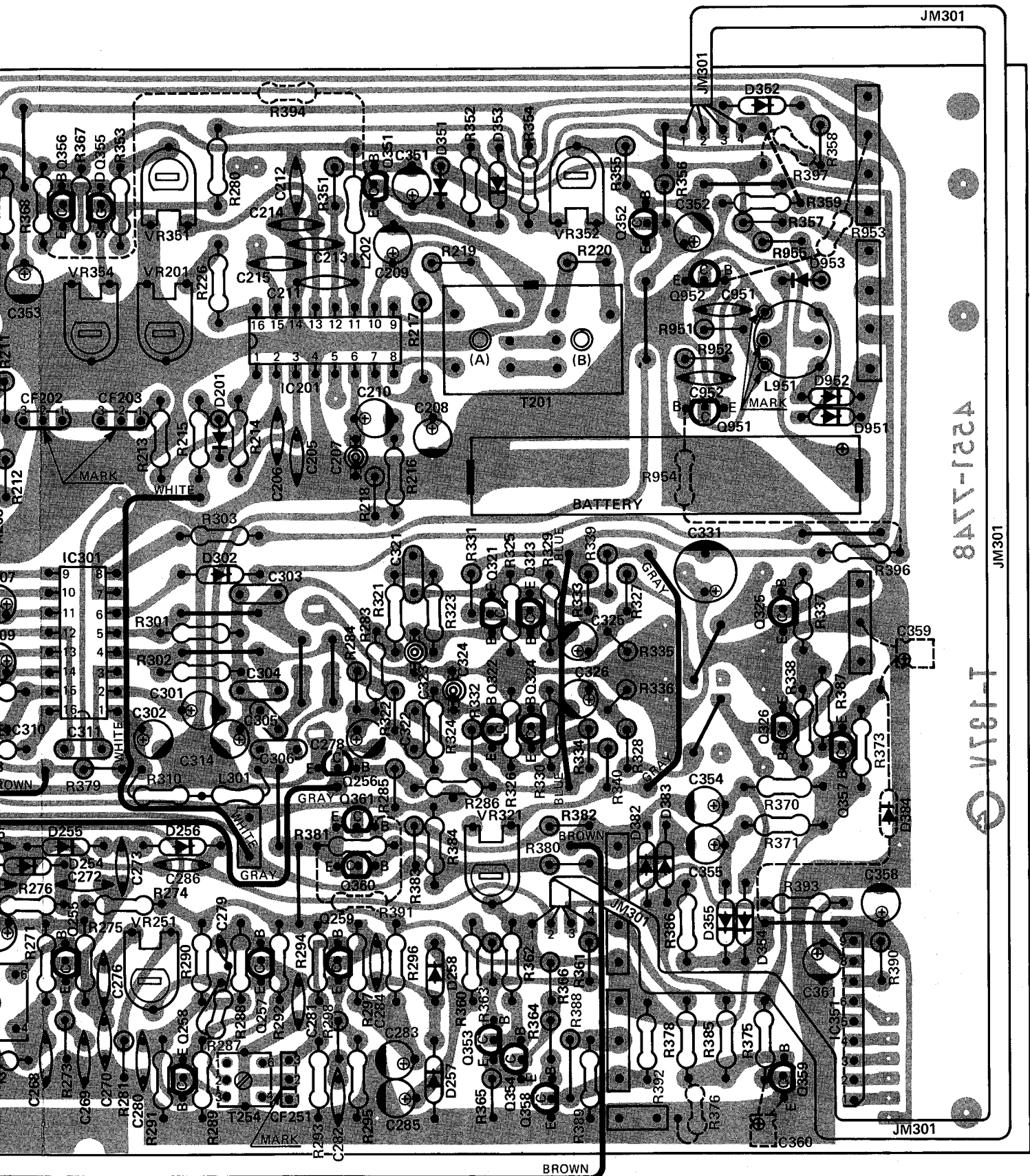

4221-2248

JM301

1931

JM301

BROWN

**TUNER P.C. BOARD**

THE FOLLOWING P.C. BOARD IS APPLIED TO MULTI VOLTAGE UNIT.

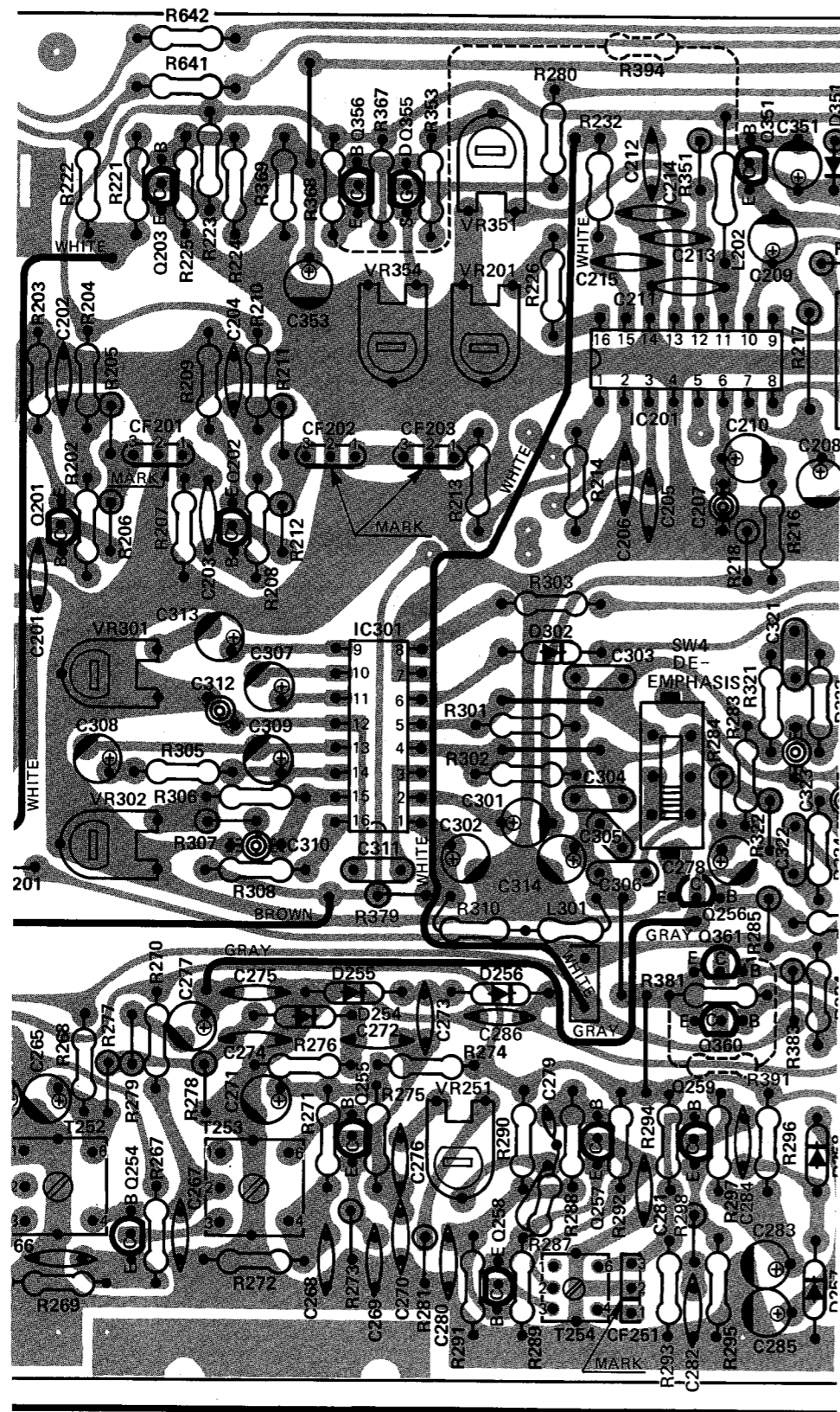

**TUNER P.C. BOARD**

Ref. No.	Part No.	Description
<b>RESISTORS</b>		
VR201, 301	5101-2037187	Variable Resistor, 20 k ohm
VR251, 351, 352	5101-5037187	Variable Resistor, 50 k ohm
VR302, 354	5101-5027187	Variable Resistor, 5 k ohm
VR321	5101-1017187	Variable Resistor, 100 ohm
<b>CAPACITORS</b>		
TC251, 252	5371-49	Trimmer Capacitor
<b>INTEGRATED CIRCUITS</b>		
IC201	5652-HA11225	HA11225 FM IF Amp./FM Det.
IC301	5652-KB4437	KB4437 FM Multiplex
IC351	5652-AN6875	AN6875 Signal Strength Display Driver
<b>TRANSISTORS</b>		
Q201, 202	5613-2058(N)	2SC2058(N)or(P) FM IF Amp.
Q203, 256, 352, 358	5613-2603(F)	2SC2603(F) FM AGC, AM Signal Switching, Mono/Stereo Switching, Quartz Lock Indicator Driver
Q251	5616-2SK168(E)	F.E.T., 2SK168(E) AM Osc. Buffer
Q252	5613-2058(N)	2SC2058(N)or(P) AM Osc.
Q253, 254, 255	5613-2058(N)	2SC2058(N)or(P) AM IF Amp.
Q257, 258, 259	5613-2603(F)	2SC2603(F) Auto Scan Stop Control Amp.
Q321, 322	5611-1115(F)	2SA1115(F) } MPX Output Amp.
Q323, 324	5613-2603(F)	2SC2603(F) }
Q325, 326, 359	5613-2603(F)	2SC2603(F) } FM Muting
Q357	5611-999(F)	2SA999(F) }
Q351, 353, 354	5613-2603(F)	2SC2603(F) Synthesizer/Quartz Lock Switching
Q355	5616-2SK163(M)	F.E.T., 2SK163(M) } Signal Strength Display Level Amp.
Q356	5611-999(F)	2SA999(F) }
Q360, 361	5611-999(F)	2SA999(F) AM Voltage Supply, FM Voltage Supply
Q615, 616	5616-2SK163(M)	F.E.T., 2SK163(M) } Phono Muting
Q617	5613-2603(F)	2SC2603(F) }
Q951, 952	5613-2603(F)	2SC2603(F) Memory IC Back Up Osc.
<b>DIODES</b>		
D201, 253, 257, 258, 351, 352, 353, 354, 355, 382, 383, 384, 605, 951, 952, 953	5636-1S2473	1S2473
D251/252	5633-KV1226	KV1226
D254, 255, 256	5631-1N34A	1N34A
D302	5635-RD6R2EB1	RD6.2EB1
<b>COILS</b>		
L201, 253	5995-3R3254	RF Choke
L202	5995-101254	RF Choke
L251	5923-71020	AM Osc.
L301	5995-100254	RF Choke
L951	5933-70215	Back Up Osc.
<b>TRANSFORMERS</b>		
T201	5574-7023	Quadrature Det.
T251, 252	5553-70111	AM IF
T253	5553-70211	AM IF
T254	5552-7037	Filter
<b>MISCELLANEOUS</b>		
CF201, 202, 203	6114-7121	FM Tuner Assembly
CF251	4196-NR-AA	Nickel Cadmium Storage Battery
	5671-7117A	Ceramic Filter, FM IF
	5671-7129A	Ceramic Filter, Filter

# TUNER P.C. BOARD

THE FOLLOWING P.C. BOARD IS APPLIED TO MULTI VOLTAGE UNIT.

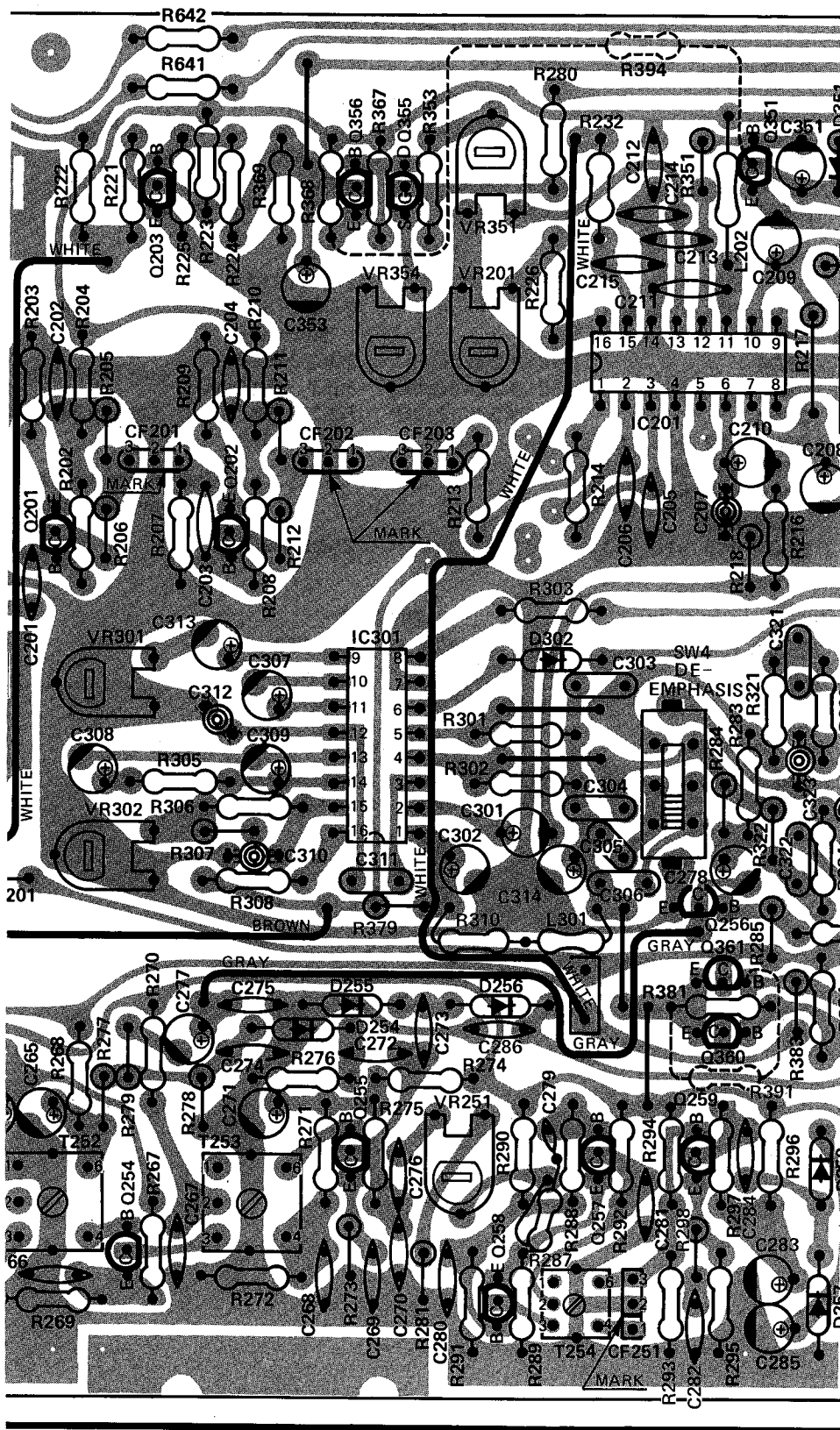



# TUNER P.C. BOARD

Ref. No.	Part No.	Description
<b>RESISTORS</b>		
VR201, 301	5101-2037187	Variable Resistor, 20 k ohm
VR251, 351, 352	5101-5037187	Variable Resistor, 50 k ohm
VR302, 354	5101-5027187	Variable Resistor, 5 k ohm
VR321	5101-1017187	Variable Resistor, 100 ohm
<b>CAPACITORS</b>		
TC251, 252	5371-49	Trimmer Capacitor
<b>INTEGRATED CIRCUITS</b>		
IC201	5652-HA11225	HA11225 FM IF Amp./FM Det.
IC301	5652-KB4437	KB4437 FM Multiplex
IC351	5652-AN6875	AN6875 Signal Strength Display Driver
<b>TRANSISTORS</b>		
Q201, 202	5613-2058(N)	2SC2058(N)or(P) FM IF Amp.
Q203, 256, 352, 358	5613-2603(F)	2SC2603(F) FM AGC, AM Signal Switching, Mono/Stereo Switching, Quartz Lock Indicator Driver
Q251	5616-2SK168(E)	F.E.T., 2SK168(E) AM Osc. Buffer
Q252	5613-2058(N)	2SC2058(N)or(P) AM Osc.
Q253, 254, 255	5613-2058(N)	2SC2058(N)or(P) AM IF Amp.
Q257, 258, 259	5613-2603(F)	2SC2603(F) Auto Scan Stop Control Amp.
Q321, 322	5611-1115(F)	2SA1115(F) } MPX Output Amp.
Q323, 324	5613-2603(F)	2SC2603(F) }
Q325, 326, 359	5613-2603(F)	2SC2603(F) } FM Muting
Q357	5611-999(F)	2SA999(F) }
Q351, 353, 354	5613-2603(F)	2SC2603(F) Synthesizer/Quartz Lock Switching
Q355	5616-2SK163(M)	F.E.T., 2SK163(M) } Signal Strength Display Level Amp.
Q356	5611-999(F)	2SA999(F) }
Q360, 361	5611-999(F)	2SA999(F) AM Voltage Supply, FM Voltage Supply
Q615, 616	5616-2SK163(M)	F.E.T., 2SK163(M) } Phono Muting
Q617	5613-2603(F)	2SC2603(F) }
Q951, 952	5613-2603(F)	2SC2603(F) Memory IC Back Up Osc.
<b>DIODES</b>		
D201, 253, 257, 258, 351, 352, 353, 354, 355, 382, 383, 384, 605, 951, 952, 953	5636-1S2473	1S2473
D251/252	5633-KV1226	KV1226
D254, 255, 256	5631-1N34A	1N34A
D302	5635-RD6R2EB1	RD6.2EB1
<b>COILS</b>		
L201, 253	5995-3R3254	RF Choke
L202	5995-101254	RF Choke
L251	5923-71020	AM Osc.
L301	5995-100254	RF Choke
L951	5933-70215	Back Up Osc.
<b>TRANSFORMERS</b>		
T201	5574-7023	Quadrature Det.
T251, 252	5553-70111	AM IF
T253	5553-70211	AM IF
T254	5552-7037	Filter
<b>MISCELLANEOUS</b>		
	6114-7121	FM Tuner Assembly
	4196-NR-AA	Nickel Cadmium Storage Battery
CF201, 202, 203	5671-7117A	Ceramic Filter, FM IF
CF251	5671-7129A	Ceramic Filter, Filter

STATION DISPLAY CONTROL P.C. BOARD

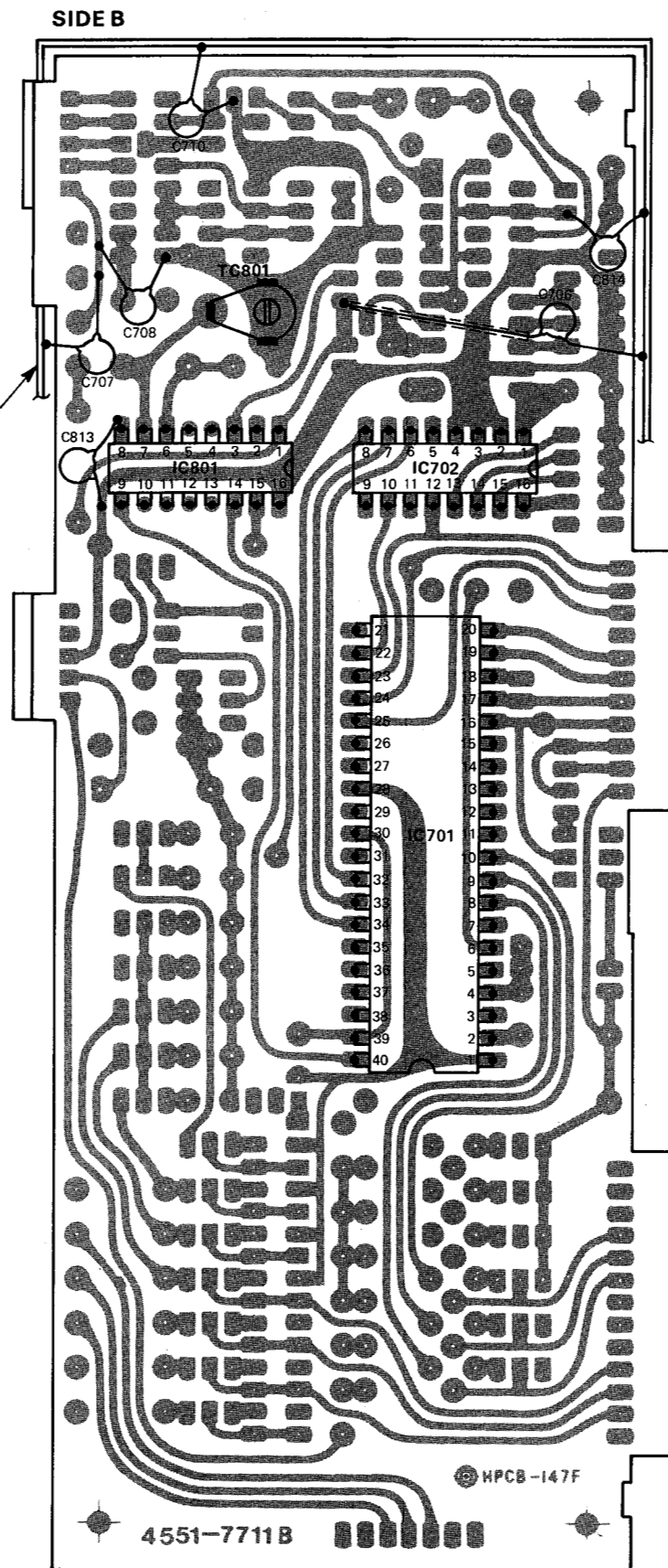
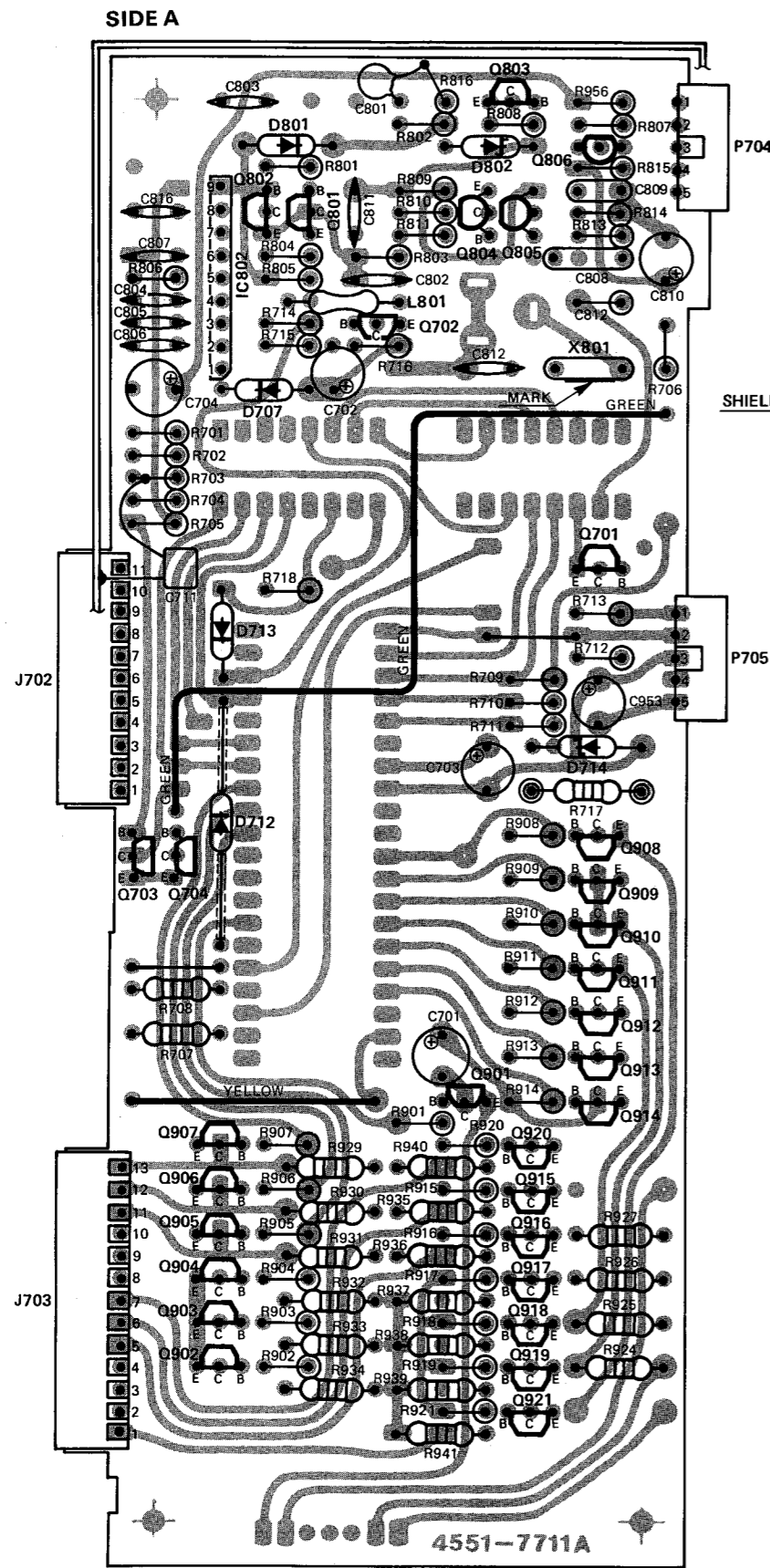

Ref. No.	Part No.	Description
<b>CAPACITORS</b>		
TC801	5371-59	Trimmer Capacitor
<b>INTEGRATED CIRCUITS</b>		
IC701	5654-MN1400SJ	MN1400SJ Synthesizer Controller
IC702	5654-MN1203	MN1203 Memory
IC801	5654-MN6142	MN6142 PLL
IC802	5654-AN6821	AN6821 Pre-Scaler
<b>TRANSISTORS</b>		
Q701, 802	5613-2603(F)	2SC2603(F) Switching, Pre-Scaler Buffer
Q702, 703, 704, 801, 803	5611-1115(F)	2SA1115(F) Switching, AM Osc. Amp., Switching
Q804	5613-2320L(F)	2SC2320L(F) } Low Pass Filter
Q805	5616-2SK68(M)	F.E.T., 2SK68(M) }
Q806	5616-2SK163(N)	F.E.T., 2SK163(N) Current Regulator
Q901, 902, 903, 904, 905, 906, 907, 915, 916, 917, 918, 919, 920, 921	5611-1115(F)	2SA1115(F) } Station Display/Preset Memory Indicator Driver
Q908, 909, 910, 911, 912, 913, 914	5613-2603(F)	2SC2603(F)
<b>DIODES</b>		
D707, 712, 713, 801	5631-1S2473	1S2473
D714	5635-RD6R2FB	Zener, RD6.2FB
D802	5635-HZ27-3	Zener, HZ27-3
<b>MISCELLANEOUS</b>		
X801	5691-01152019	Crystal Osc., 11.52MHz
L801	5995-100325	Coil, Choke

# STATION DISPLAY CONTROL P.C. BOARD

SIDE A

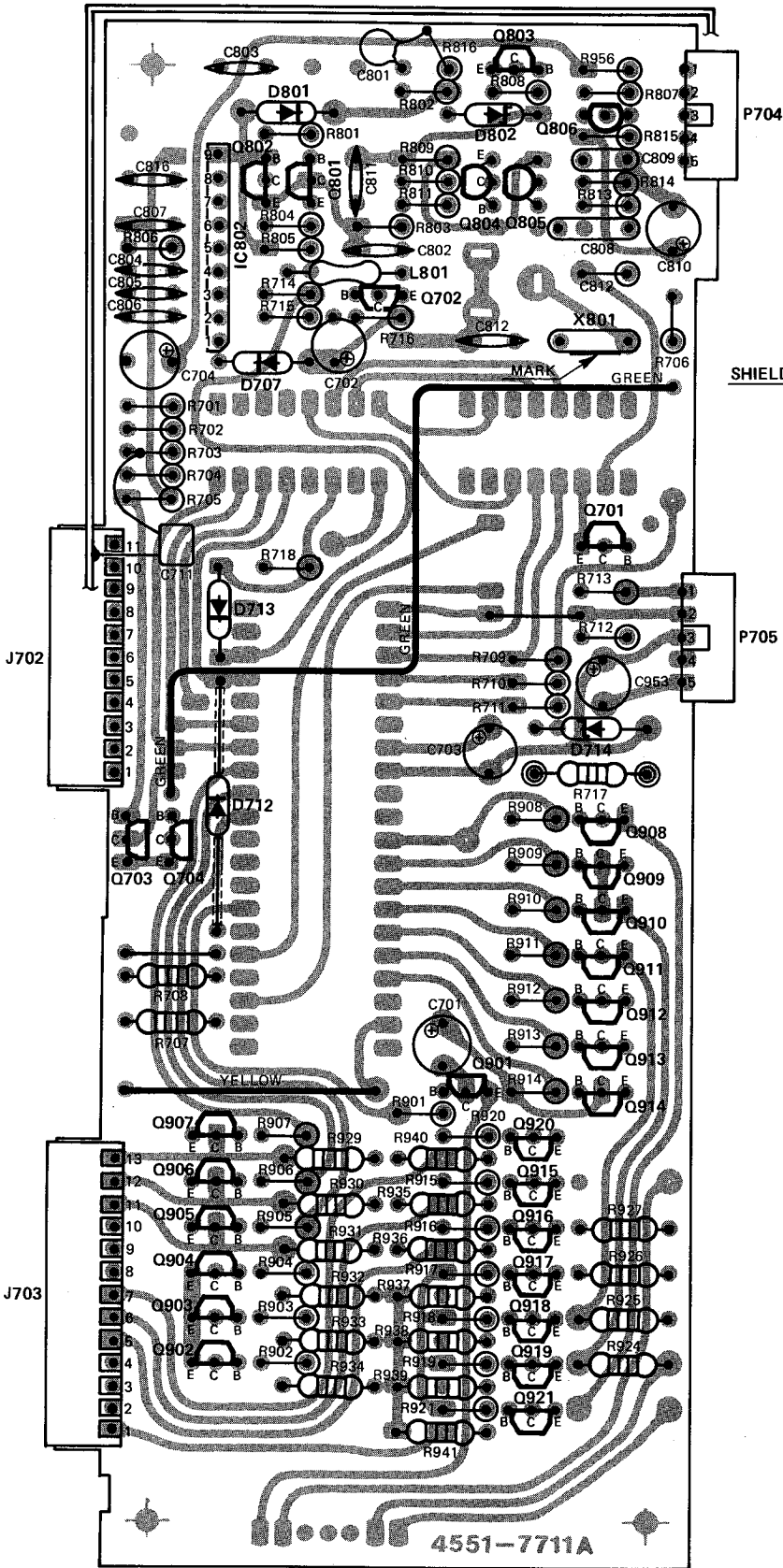

SIDE B

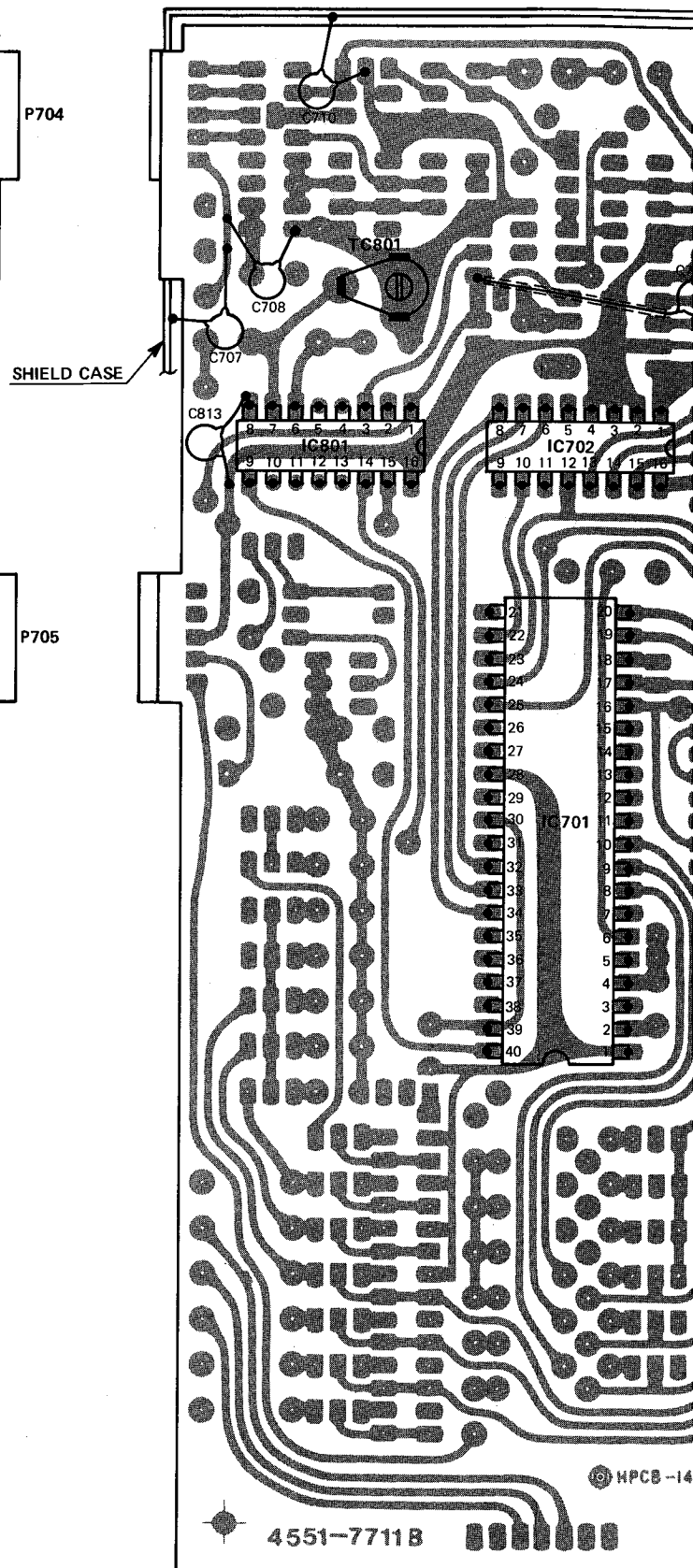

HPCB-14

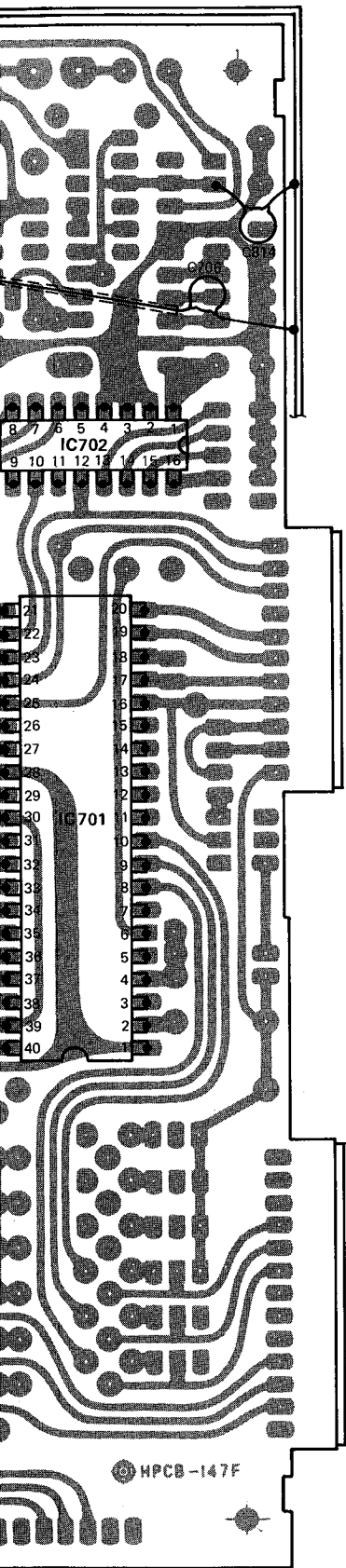

Ref. No.

Part No.

Description

**CAPACITORS**

TC801 5371-59 Trimmer Capacitor

**INTEGRATED CIRCUITS**

IC701 5654-MN1400SJ MN1400SJ Synthesizer Controller  
 IC702 5654-MN1203 MN1203 Memory  
 IC801 5654-MN6142 MN6142 PLL  
 IC802 5654-AN6821 AN6821 Pre-Scaler

**TRANSISTORS**

Q701, 802 5613-2603(F) 2SC2603(F) Switching, Pre-Scaler Buffer  
 Q702, 703, 704, 801, 803 5611-1115(F) 2SA1115(F) Switching, AM Osc. Amp.,  
 Switching  
 Q804 5613-2320L(F) 2SC2320L(F) } Low Pass Filter  
 Q805 5616-2SK68(M) F.E.T., 2SK68(M) }  
 Q806 5616-2SK163(N) F.E.T., 2SK163(N) Current Regulator  
 Q901, 902, 903, 904, 905, 906, 907, 915, 916, 917, 918, 919, 920, 921 5611-1115(F) 2SA1115(F) } Station Display/Preset  
 Memory Indicator Driver  
 Q908, 909, 910, 911, 912, 913, 914 5613-2603(F) 2SC2603(F)

**DIODES**

D707, 712, 713, 801 5631-1S2473 1S2473  
 D714 5635-RD6R2FB Zener, RD6.2FB  
 D802 5635-HZ27-3 Zener, HZ27-3

**MISCELLANEOUS**

X801 5691-01152019 Crystal Osc., 11.52MHz  
 L801 5995-100325 Coil, Choke

**PRESET MEMORY SWITCH P.C. BOARD**

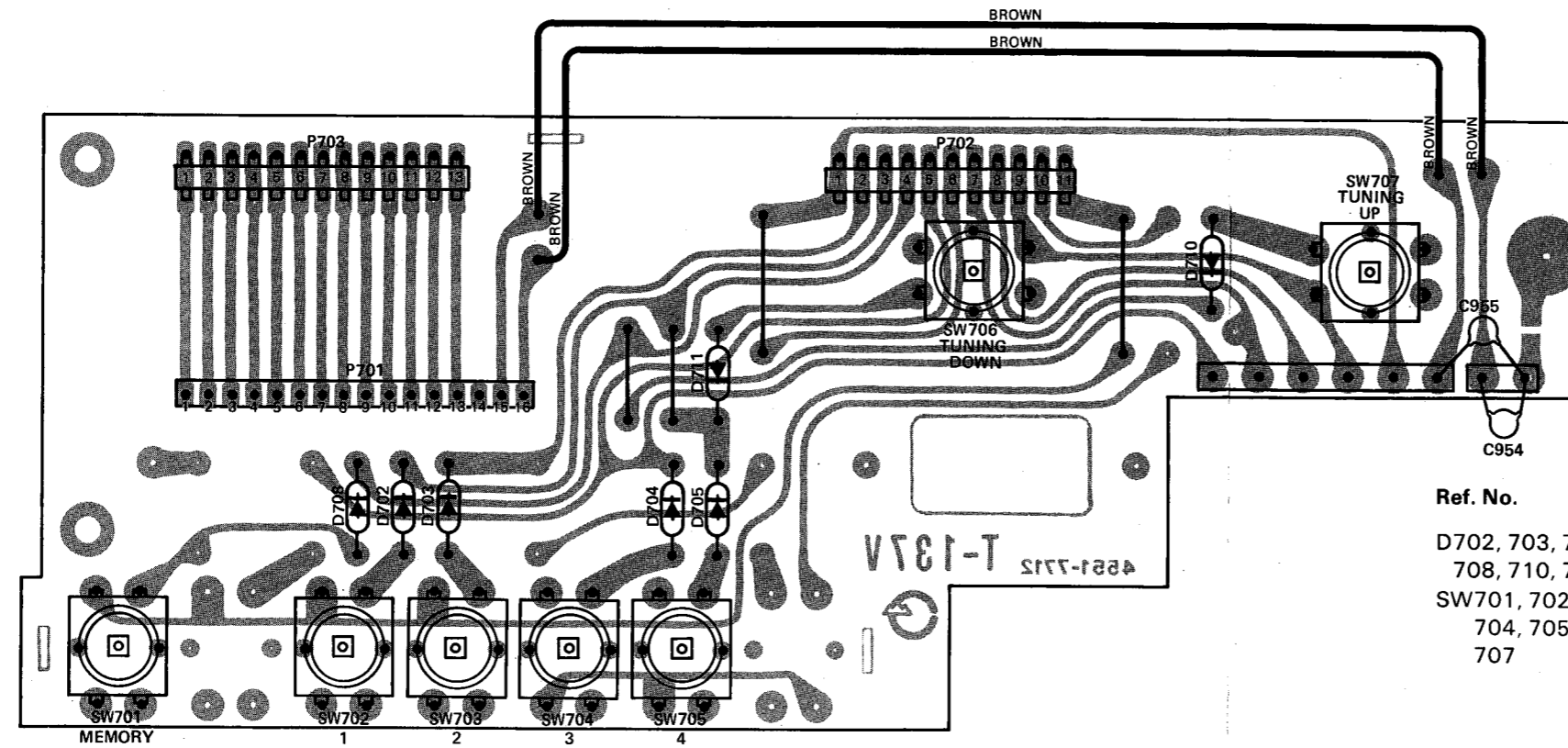

Ref. No.	Part No.	Description
D702, 703, 704, 705, 708, 710, 711	5631-1S2473	Diode, 1S2473
SW701, 702, 703, 704, 705, 706, 707	4431-01010170	Push Switch, FM/AM Preset Memory, Tuning Down, Tuning Up

**SPEAKERS SWITCH P.C. BOARD**

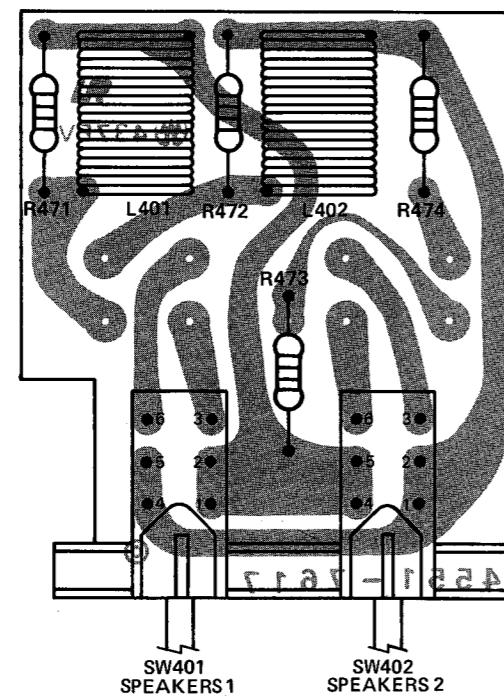

Ref. No.	Part No.	Description
L401, 402	5991-7125	Coil, RF Choke
SW401, 402	4431-02047451	Push Switch, Speakers 1, Speakers 2

**JACK P.C. BOARD**

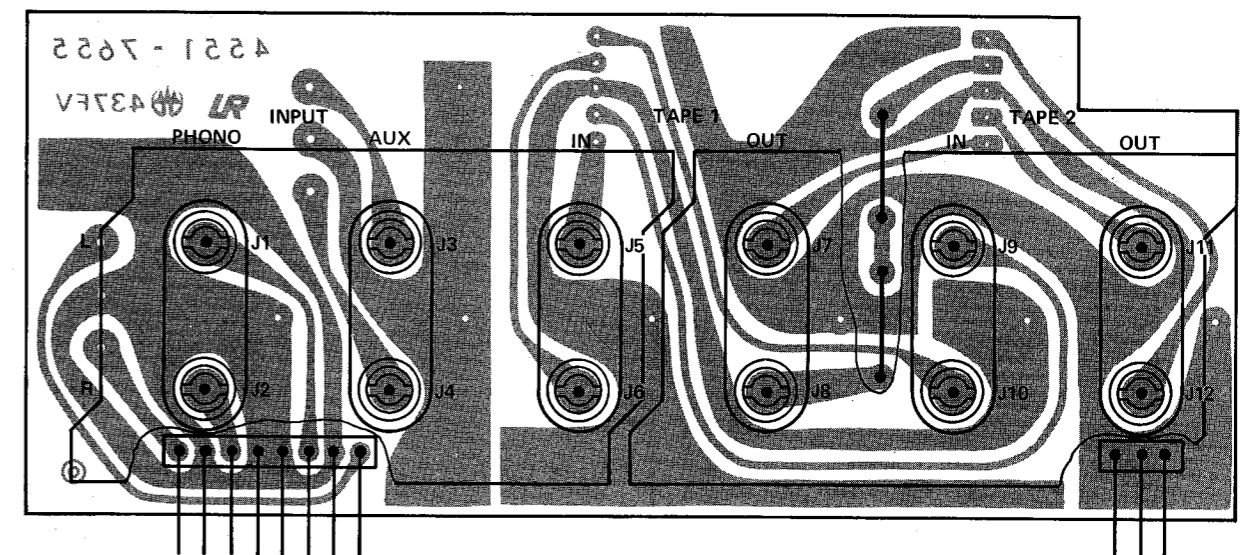

Ref. No.	Part No.	Description
J1, 2, 3, 4, 5, 6, 7, 8, 9, 10, 11, 12	4486-5	6-Pin Jack, Phono, AUX, Tape 1, Tape 2

**PRESET MEMORY SWITCH P.C. BOARD**

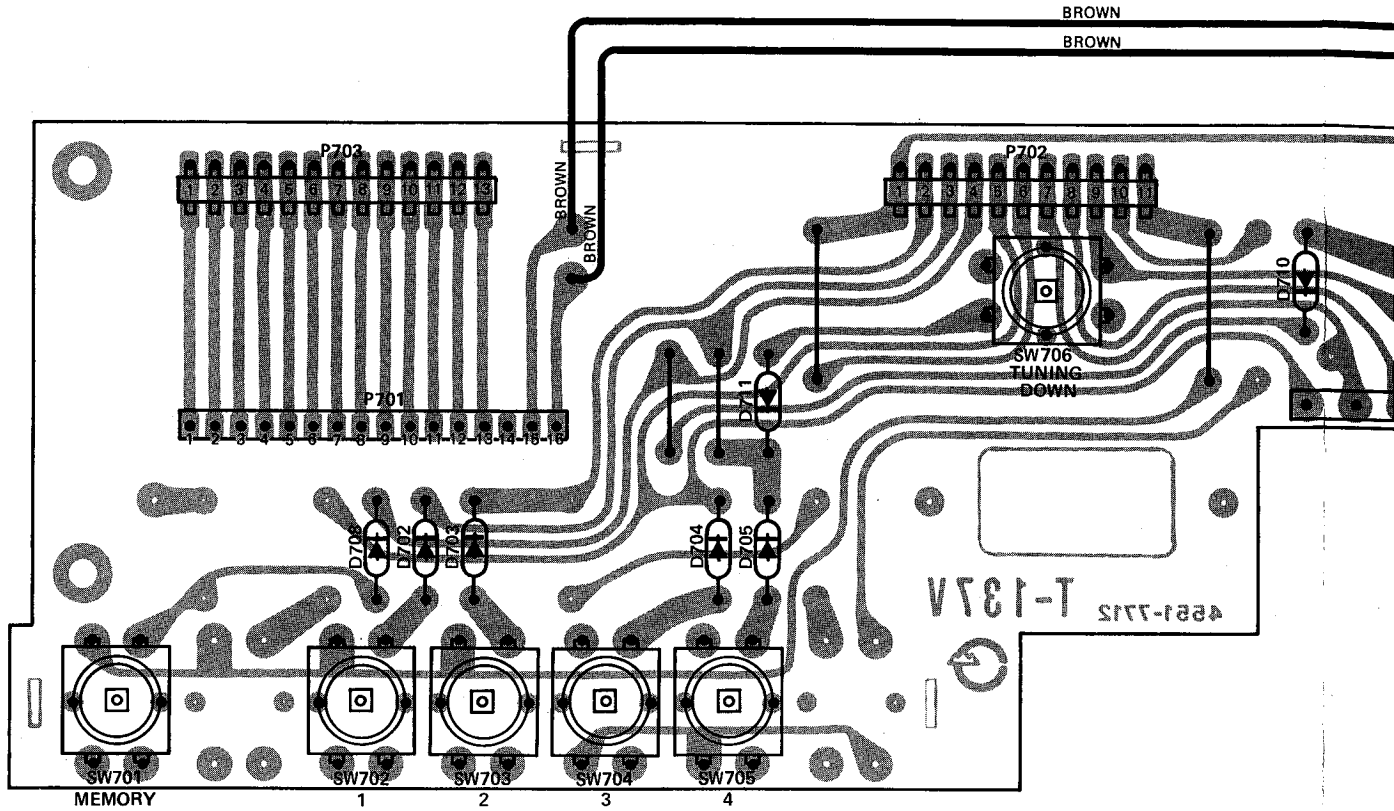

**SPEAKERS SWITCH P.C. BOARD**

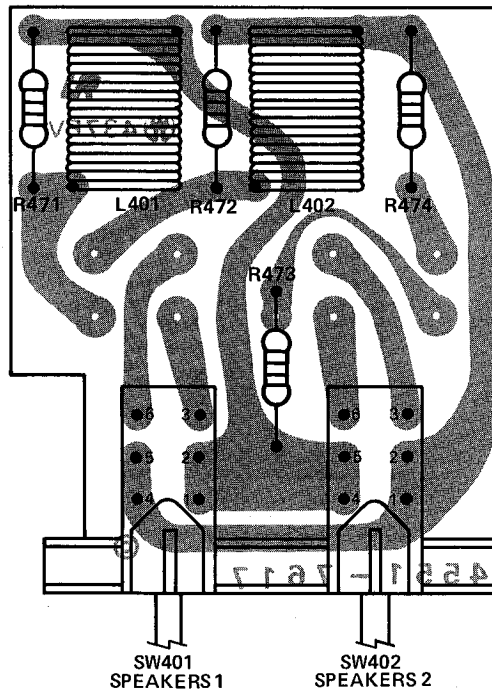

Ref. No.	Part No.	Description
L401, 402	5991-7125	Coil, RF Choke
SW401, 402	4431-02047451	Push Switch, Speakers 1, Speakers 2

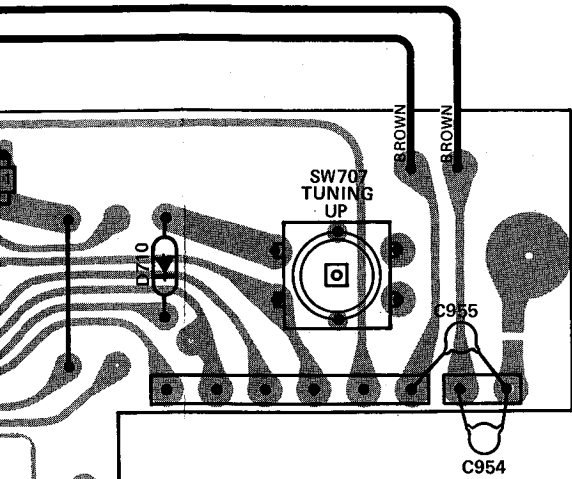

Ref. No.	Part No.	Description
D702, 703, 704, 705, 708, 710, 711	5631-1S2473	Diode, 1S2473
SW701, 702, 703, 704, 705, 706, 707	4431-01010170	Push Switch, FM/AM Preset Memory, Tuning Down, Tuning Up

### JACK P.C. BOARD

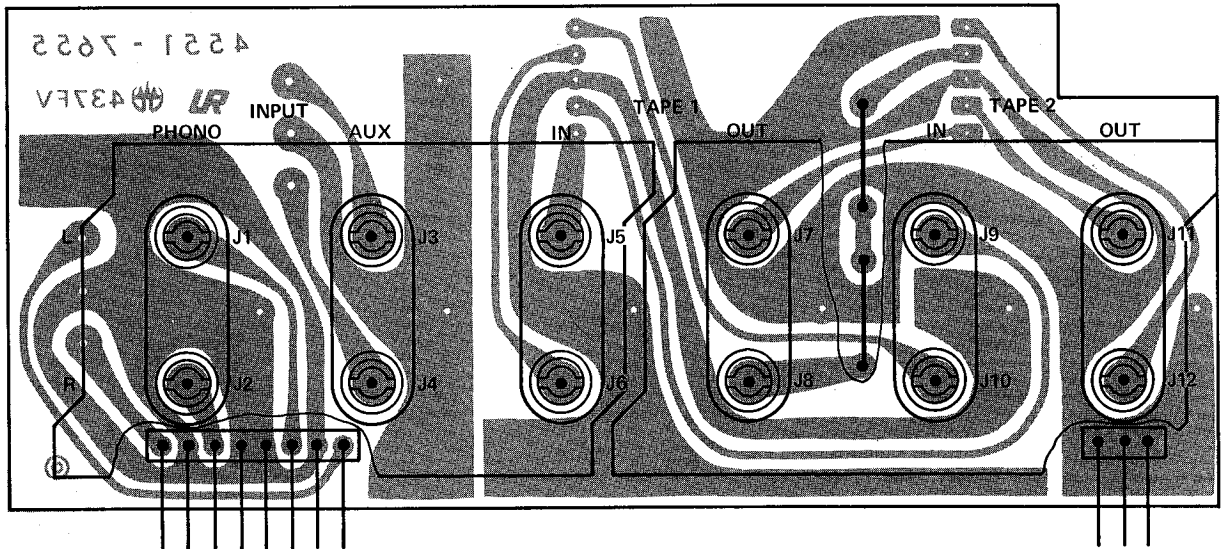

Ref. No.	Part No.	Description
J1, 2, 3, 4, 5, 6, 7, 8, 9, 10, 11, 12	4486-5	6-Pin Jack, Phono, AUX, Tape 1, Tape 2

**TONE CONTROL P.C.BOARD**

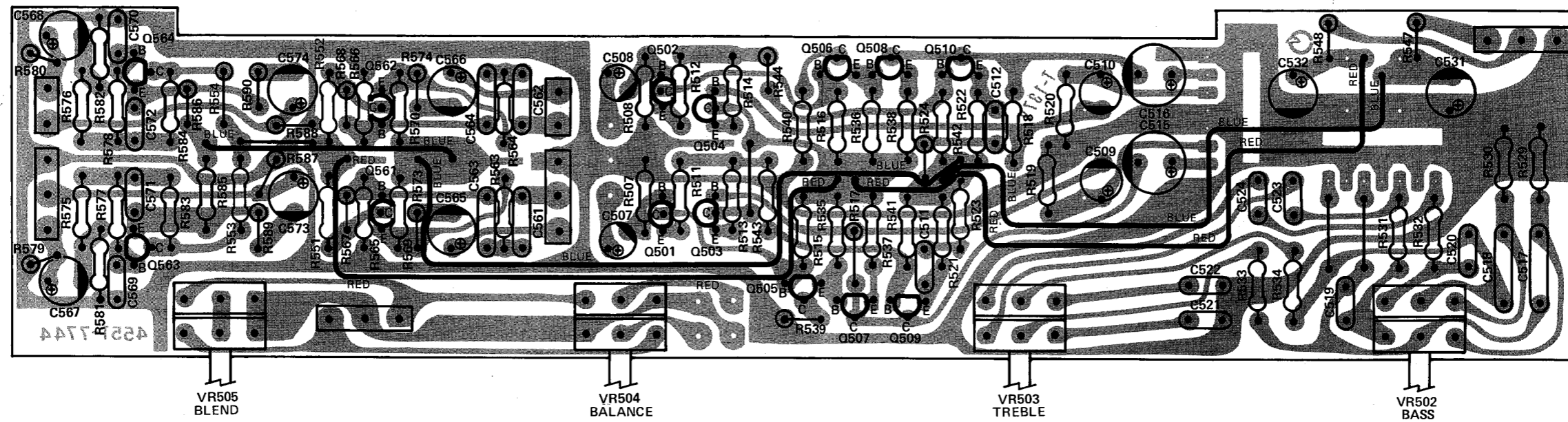

**VOLUME CONTROL P.C. BOARD**

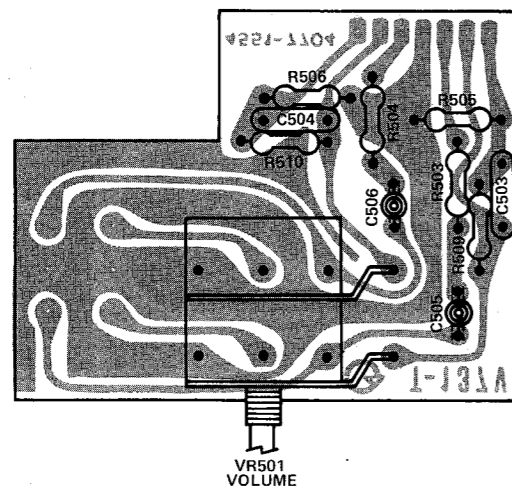

Ref. No.	Part No.	Description
VR501	5116-1047343	Variable Resistor, 100 k ohm Volume Control

**FILTER SWITCH P.C. BOARD**

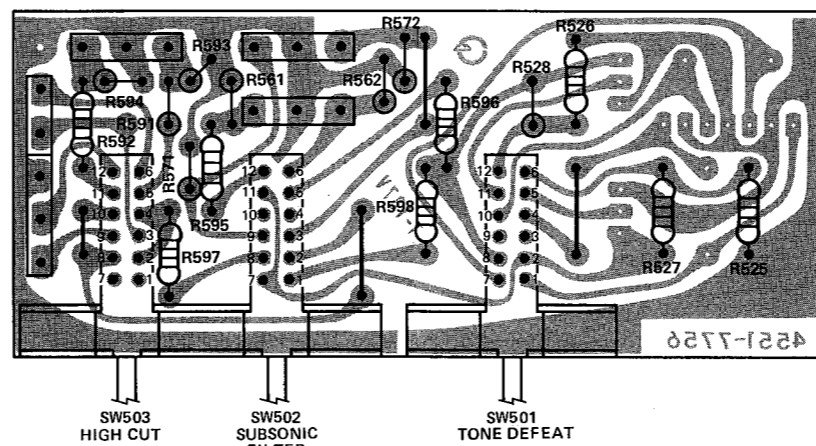

Ref. No.	Part No.	Description
SW501	4431-01047994	Push Switch, Tone Defeat
SW502, 503	4431-02087259	Push Switch, Subsonic Filter, High Cut

**LOUDNESS/MUTING SWITCH P.C. BOARD**

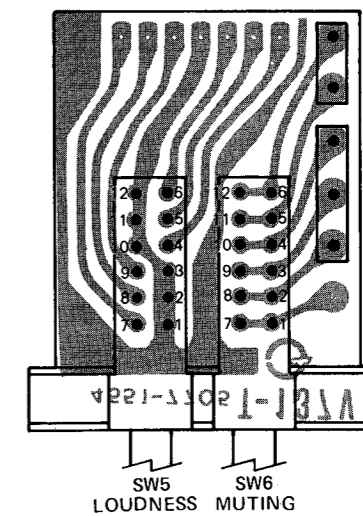

Ref. No.	Part No.	Description
SW5, 6	4431-02087160	Push Switch, Loudness, Muting



# 4431-1104

## 4431-1104

### TONE CONTROL P.C. BOARD

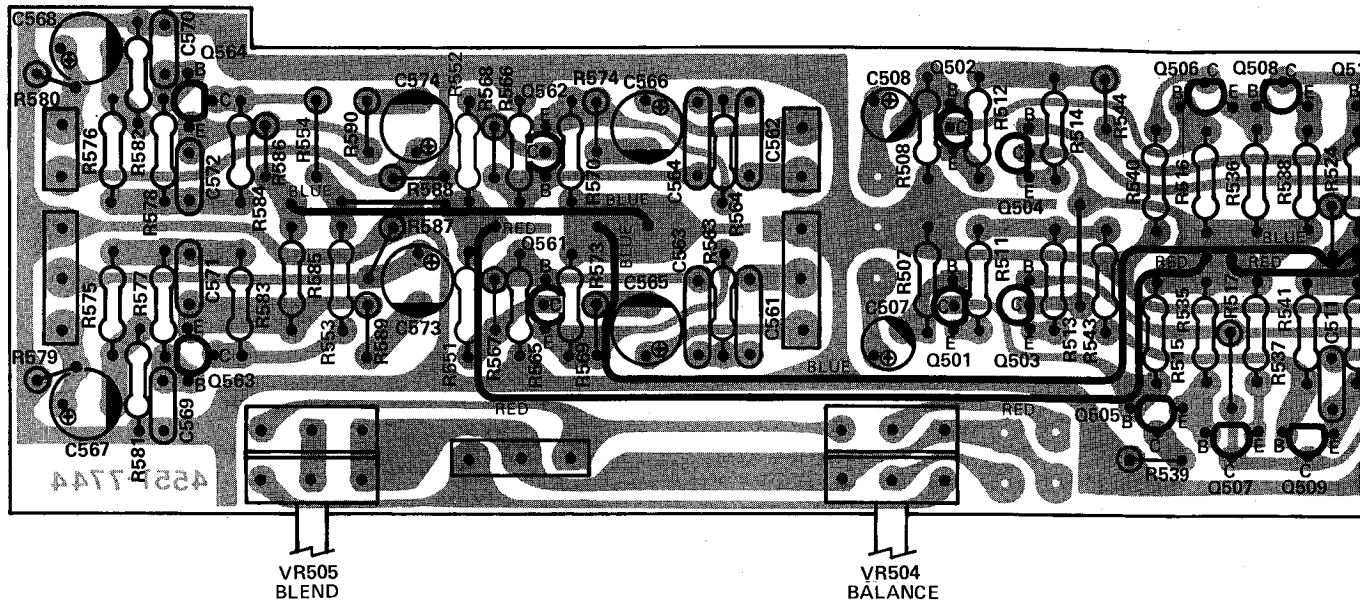

### VOLUME CONTROL P.C. BOARD

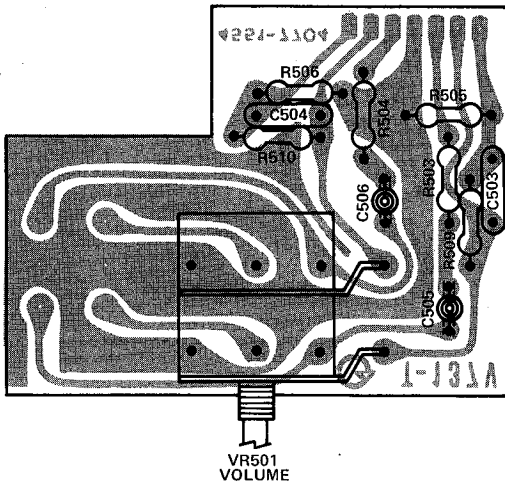

### FILTER SWITCH P.C. BOARD

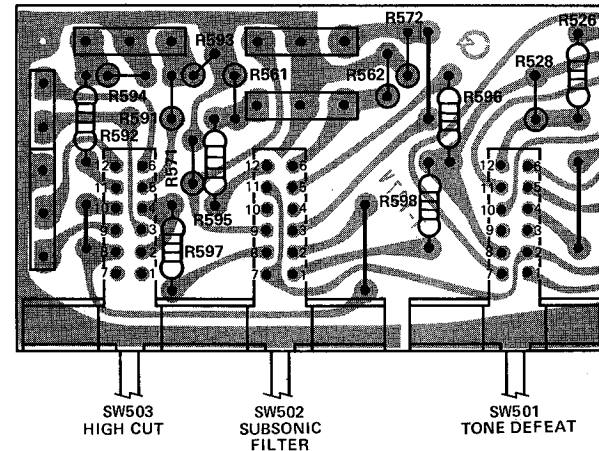

Ref. No.	Part No.	Description
VR501	5116-1047343	Variable Resistor, 100 k ohm Volume Control

Ref. No.	Part No.	Description
SW501	4431-01047994	Push Switch
SW502, 503	4431-02087259	Push Switch

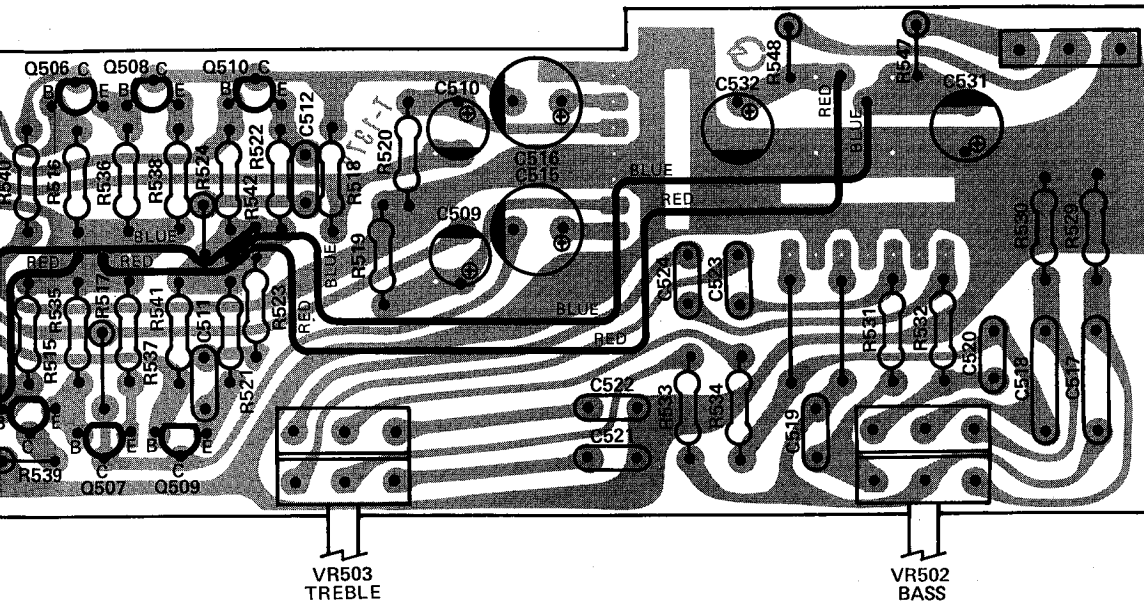

**LOUDNESS/MUTING SWITCH P.C. BOARD**

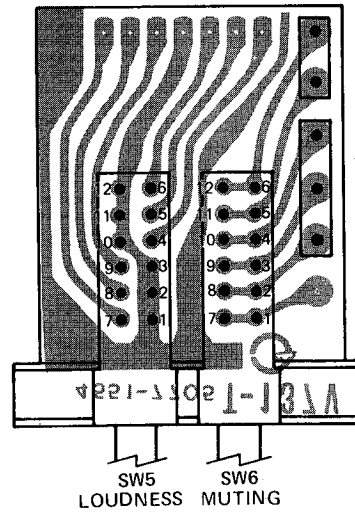
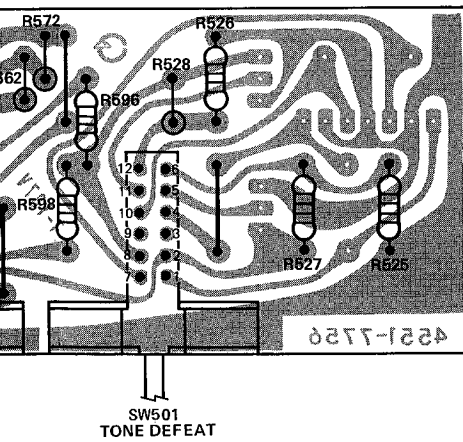

**Description**

- 47994 Push Switch, Tone Defeat
- 87259 Push Switch, Subsonic Filter, High Cut

Ref. No.	Part No.	Description
SW5, 6	4431-02087160	Push Switch, Loudness, Muting

## TONE CONTROL P.C. BOARD

Ref. No.	Part No.	Description
<b>RESISTORS</b>		
VR502	5113-1047877	Variable Resistor, 100 k ohm Bass Control
VR503	5113-5037977	Variable Resistor, 50 k ohm Treble Control
VR504	5113-50376100	Variable Resistor, 50 k ohm Balance Control
VR505	5113-2047140	Variable Resistor, 200 k ohm Blend Control
<b>TRANSISTORS</b>		
Q501, 502, 503, 504, 509, 510	5613-2603(F)	2SC2603(F) } Flat/Tone Control Amp.
Q505, 506, 507, 508	5611-1115(F)	2SA1115(F) }
Q561, 562, 563, 564	5613-2603(F)	2SC2603(F) Subsonic Filter, High-Cut Filter

## FUNCTION SWITCH P.C. BOARD

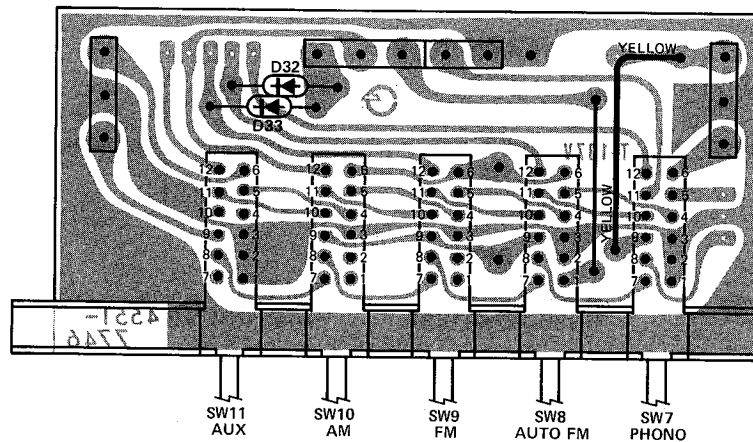

Ref. No.	Part No.	Description
D32, 33	5636-1S2473	Diode, 1S2473
SW7, 8, 9, 10, 11	4431-05207149	Push Switch, Function Selector

PHONO EQUALIZER P.C. BOARD

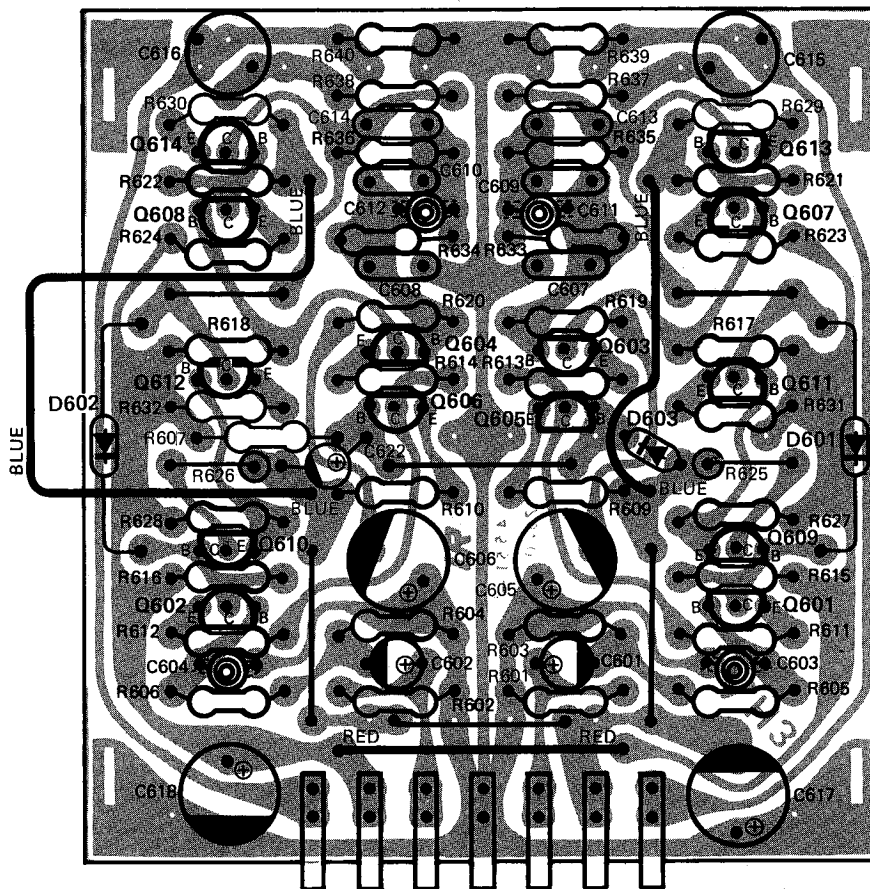

Ref. No.	Part No.	Description
<b>TRANSISTORS</b>		
Q601, 602, 603, 604	5613-2240(BL)	2SC2240(BL)
Q605, 606	5613-2603(F)	2SC2603(F)
Q607, 608, 609, 610	5611-970(BL)	2SA970(BL)
Q611, 612	5612-646(C)	2SB646(C)
Q613, 614	5614-666(C)	2SD666(C)
<b>DIODES</b>		
D601, 602	5636-1S2473	1S2473
D603	5635-RD5R1EB2	Zener, RD5.1EB2

POWER SUPPLY P.C. BOARD

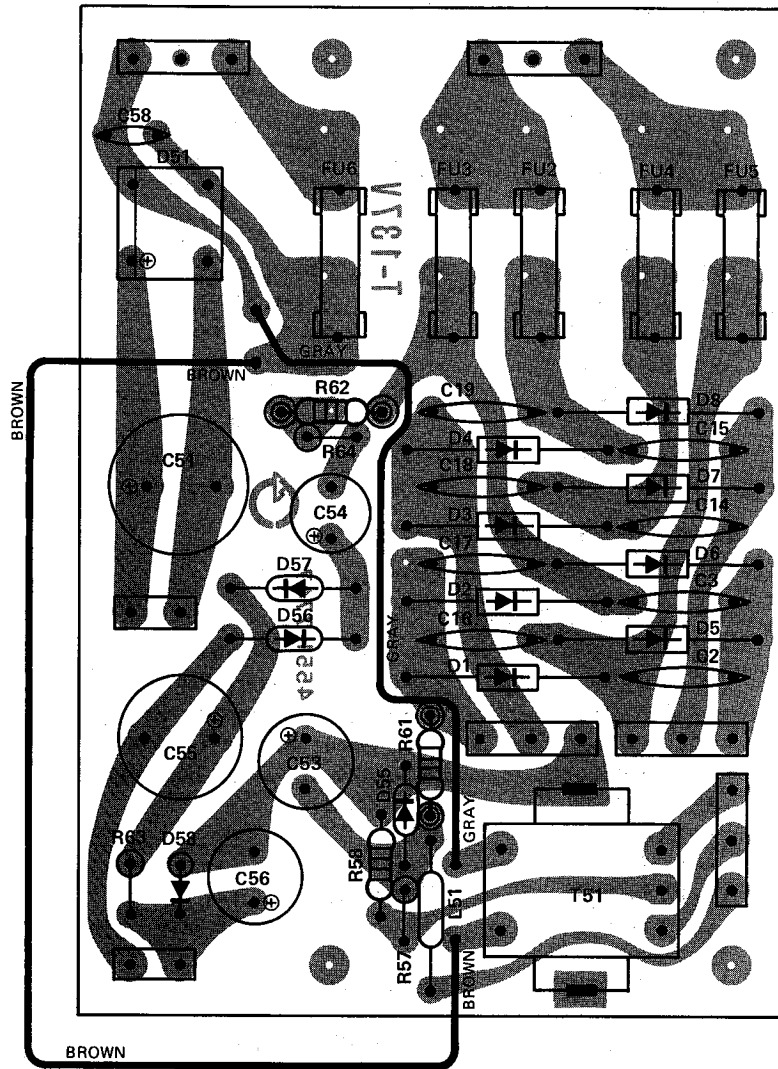

Ref. No.	Part No.	Description
<b>RESISTORS, FUSE</b>		
R61	5102-1024713	1 k ohm $\pm$ 2% 1/4W
R62	5102-1814713	180 ohm $\pm$ 2% 1/4W
<b>CAPACITORS, ELECTROLYTIC</b>		
C51	5345-228-25	2200uF +50% -10% 25V
C55	5345-477-50	470uF +50% -10% 50V
<b>DIODES</b>		
D1, 2, 3, 4, 5, 6, 7, 8	5632-ERC0402L	ERC0402L
D51	5685-S1WB10	Bridge Silicon, S1WB10
D55	5635-RD24EB2	Zener, RD24EB2
D56, 57	5636-1S2471	1S2471
D58	5635-RD30EB2	Zener, RD30EB2
<b>MISCELLANEOUS</b>		
L51	5995-101254	Coil, Choke
T51	5584-701345	Transformer, Station Display Filament
FU2, 3, 4, 5	5732-312031	Fuse, 3.15A 125V
FU6	5732-631031	Fuse, 630mA 125V

# POWER AMP. P.C. BOARD

Ref. No.	Part No.	Description
<b>RESISTORS</b>		
R11	5102-1514713	150 ohm $\pm$ 2% 1/4W Fuse
R12	5102-2214713	220 ohm $\pm$ 2% 1/4W Fuse
R13, 14	5102-1214713	120 ohm $\pm$ 2% 1/4W Fuse
R427, 428, 431, 432, 433, 434, 439, 440, 445, 446, 447, 448	5102-1014713	100 ohm $\pm$ 2% 1/4W Fuse
R437, 438	5102-8214713	820 ohm $\pm$ 2% 1/4W Fuse
R449, 450, 451, 452	5102-2R2579	2.2 ohm $\pm$ 5% 1/4W Fuse
R453, 454, 455, 456	5102-1504713	15 ohm $\pm$ 2% 1/4W Fuse
R461, 462	5102-5605114	56 ohm $\pm$ 5% 1/2W Fuse
R463/465, 464/466	5273-R22672	0.22 ohm $\pm$ 10% 3W $\times$ 2 Cement (Special Dual)
R467, 468	5175-220571	22 ohm $\pm$ 5% 3W Metal
VR401, 402	5101-10171913	Variable Resistor, 100 ohm
VR403, 404	5101-50171913	Variable Resistor, 500 ohm

## CAPACITORS, ELECTROLYTIC

C6, 7, 8, 9	5341-478F0955	4700uF $\pm$ 20% 50V
-------------	---------------	----------------------

## TRANSISTORS

Q1	5611-1115(F)	2SA1115(F) Audio Muting
Q2	5612-855(C)	2SB855(C) Voltage Regulator
Q4, 6	5614-667(C)	2SD667(C) Voltage Regulator
Q5, 7	5612-647(C)	2SB647(C) Voltage Regulator
Q52	5613-2603(F)	2SC2603(F) Voltage Regulator
Q401, 402	5613-2320(F)	2SC2320(F)
Q403, 404, 405, 406	5613-1775(F)	2SC1775(F)
Q407, 408, 411, 412	5613-2229(Y)	2SC2229(Y)
Q409, 410, 413, 414	5611-949(Y)	2SA949(Y)
Q415, 416	5613-945(Q)	2SC945(Q)or(K)
Q417, 418, 423, 424	5611-965(O)	2SA965(O)
Q419, 420, 421, 422	5613-2235(O)	2SC2235(O)
Q425, 426	5611-1146(O)	2SA1146(O)or(Y)
Q427, 428	5613-2706(O)	2SC2706(O)or(Y)

} Power Amp.

## DIODES

D10, 411, 412, 413, 414	5636-1S2471	1S2471
D11, 13, 14	5636-1S2472	1S2472
D15, 16	5635-RD24EB2	Zener, RD24EB2
D18, 19	5635-RD20EB2	Zener, RD20EB2
D52	5636-1S2473	1S2473
D53	5635-RD6R2EB2	Zener, RD6.2EB2
D54	5635-RD6R8EB2	Zener, RD6.8EB2
D401, 402	5635-RD12EB2	Zener, RD12EB2
D405, 406, 407, 408	5632-ERB12-02	ERB12-02
D409, 410	5641-MV12YM	Varistor, MV12YM
D415, 416, 417, 418	5635-RD6R2EB	Zener, RD6.2EB

## MISCELLANEOUS

CB401, 402	4361-252014	Speaker Protector
L403, 404, 405, 406	5597-35502	Ferrite Bead

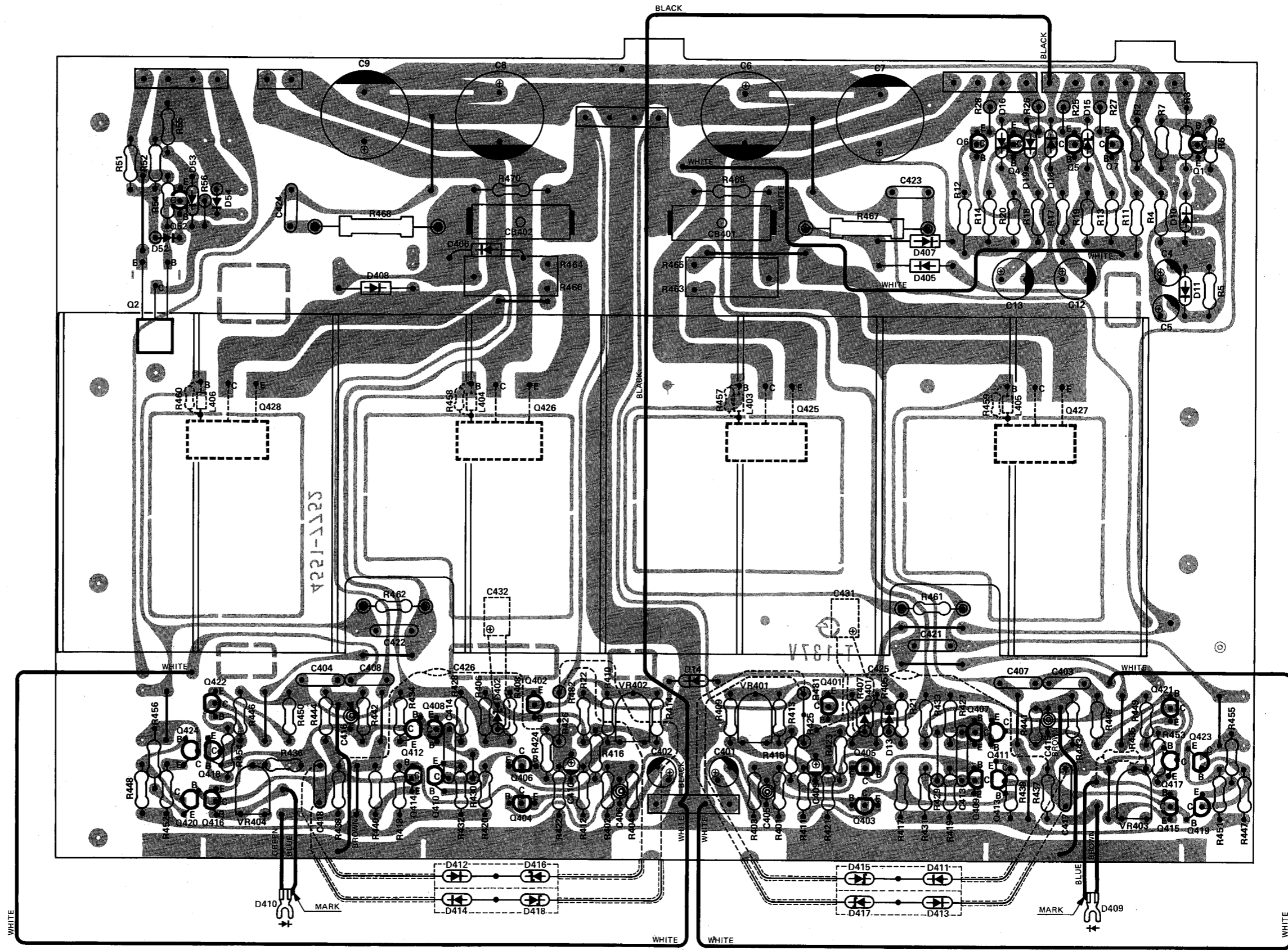

POWER AMP. P.C.BOARD

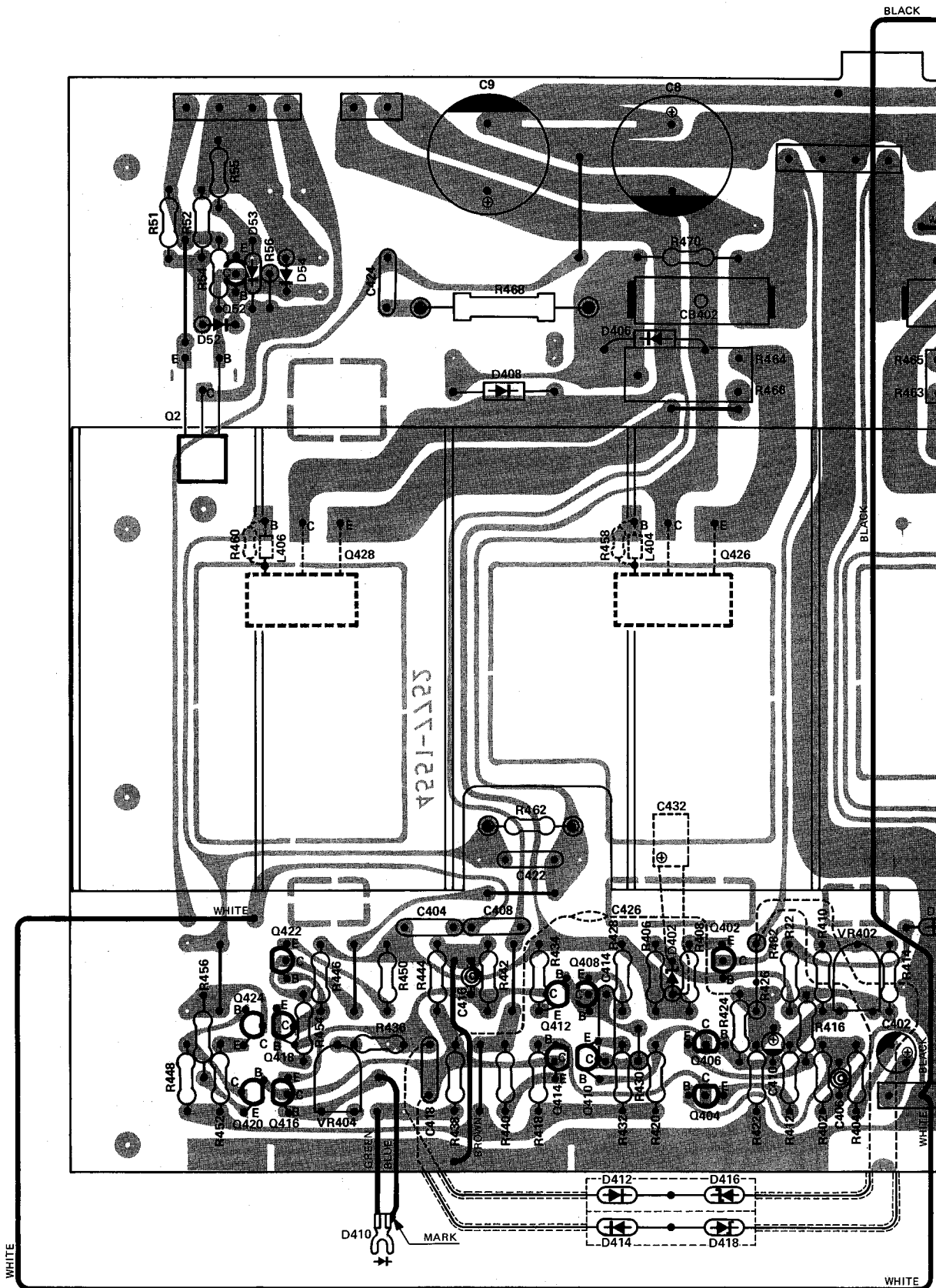



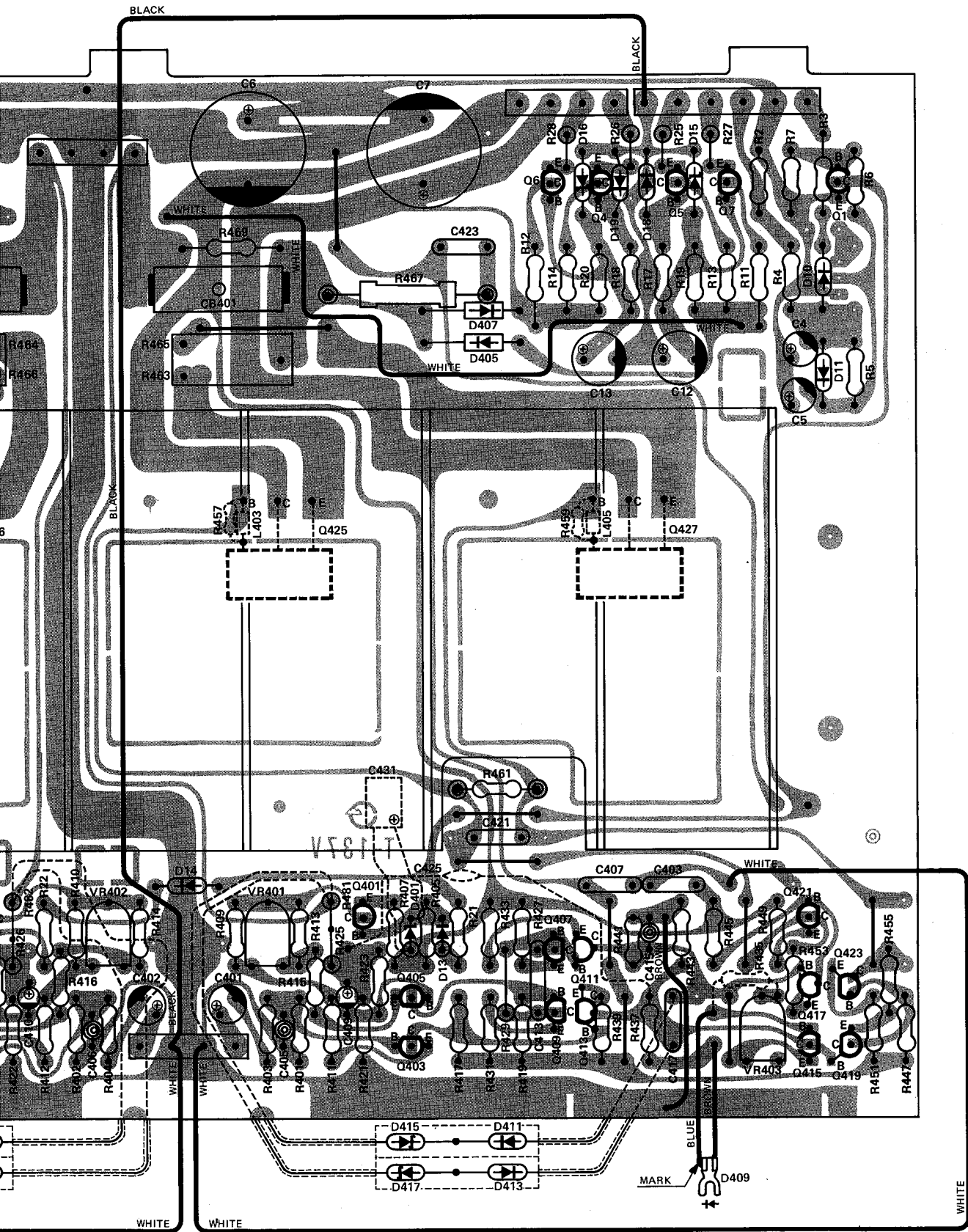

POWER AMP. P.C. BOARD

THE FOLLOWING P.C. BOARD IS APPLIED TO MULTI VOLTAGE UNIT.

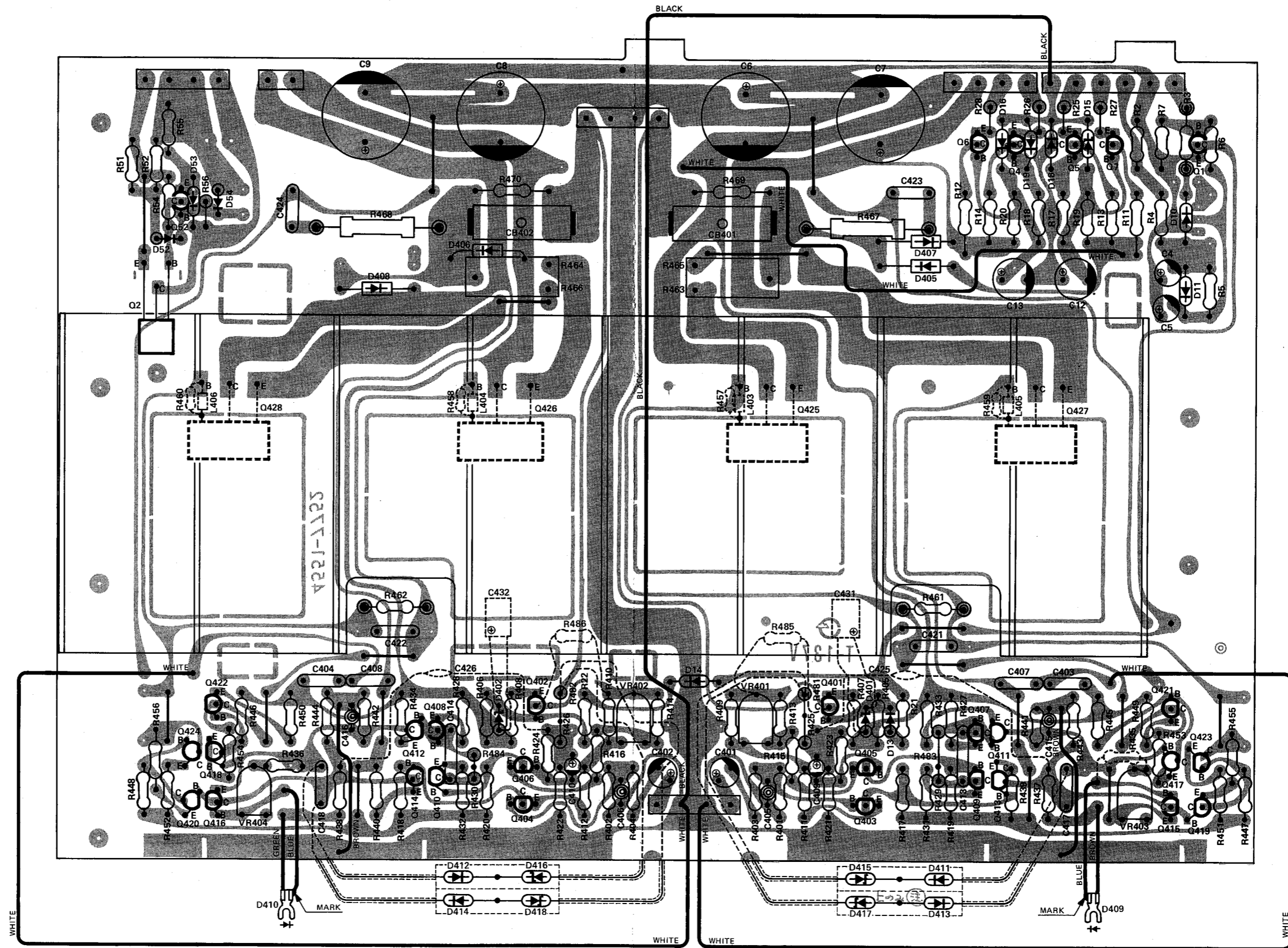

# POWER AMP. P.C. BOARD

THE FOLLOWING P.C. BOARD IS APPLIED TO MULTI VOLTAGE UNIT.

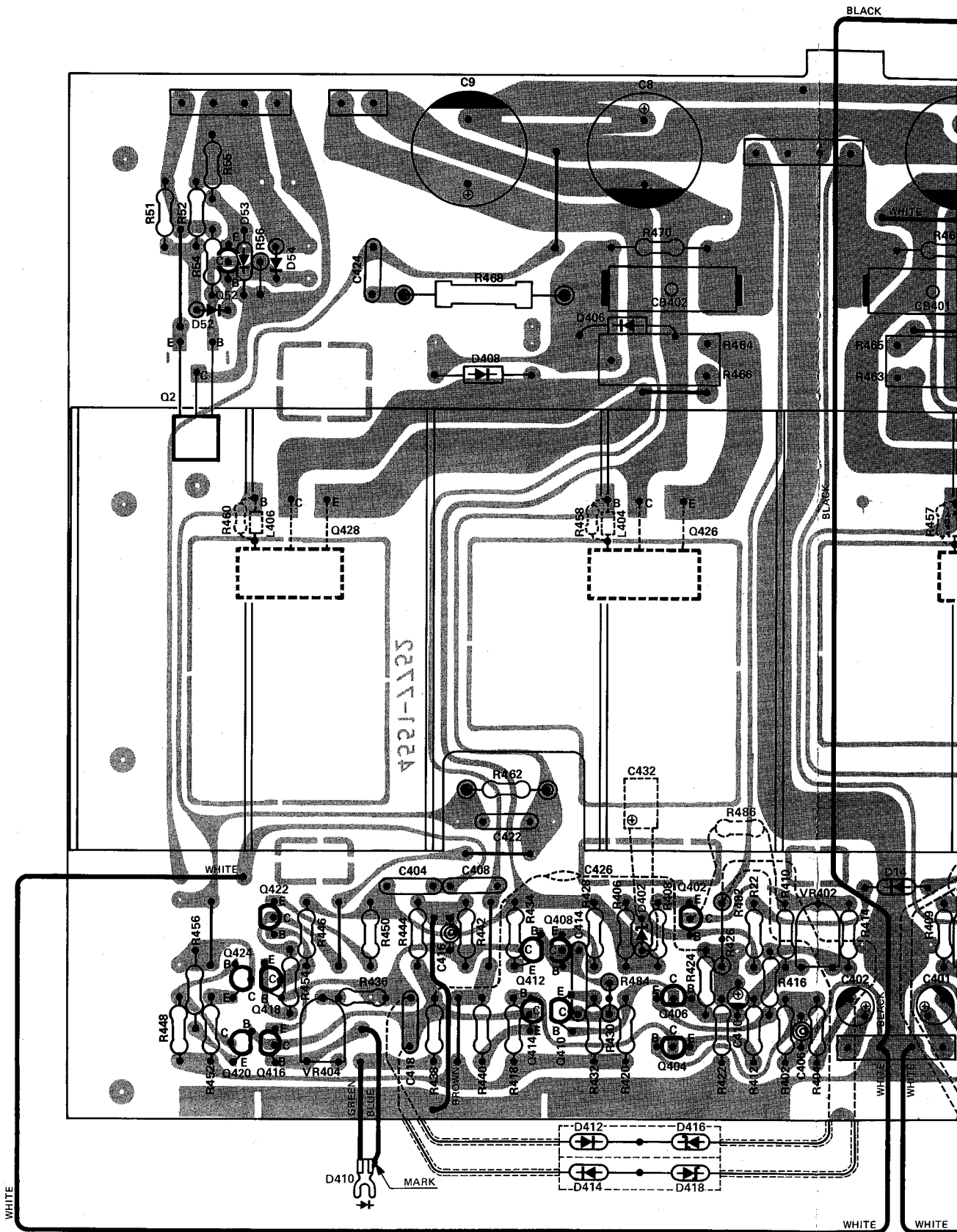

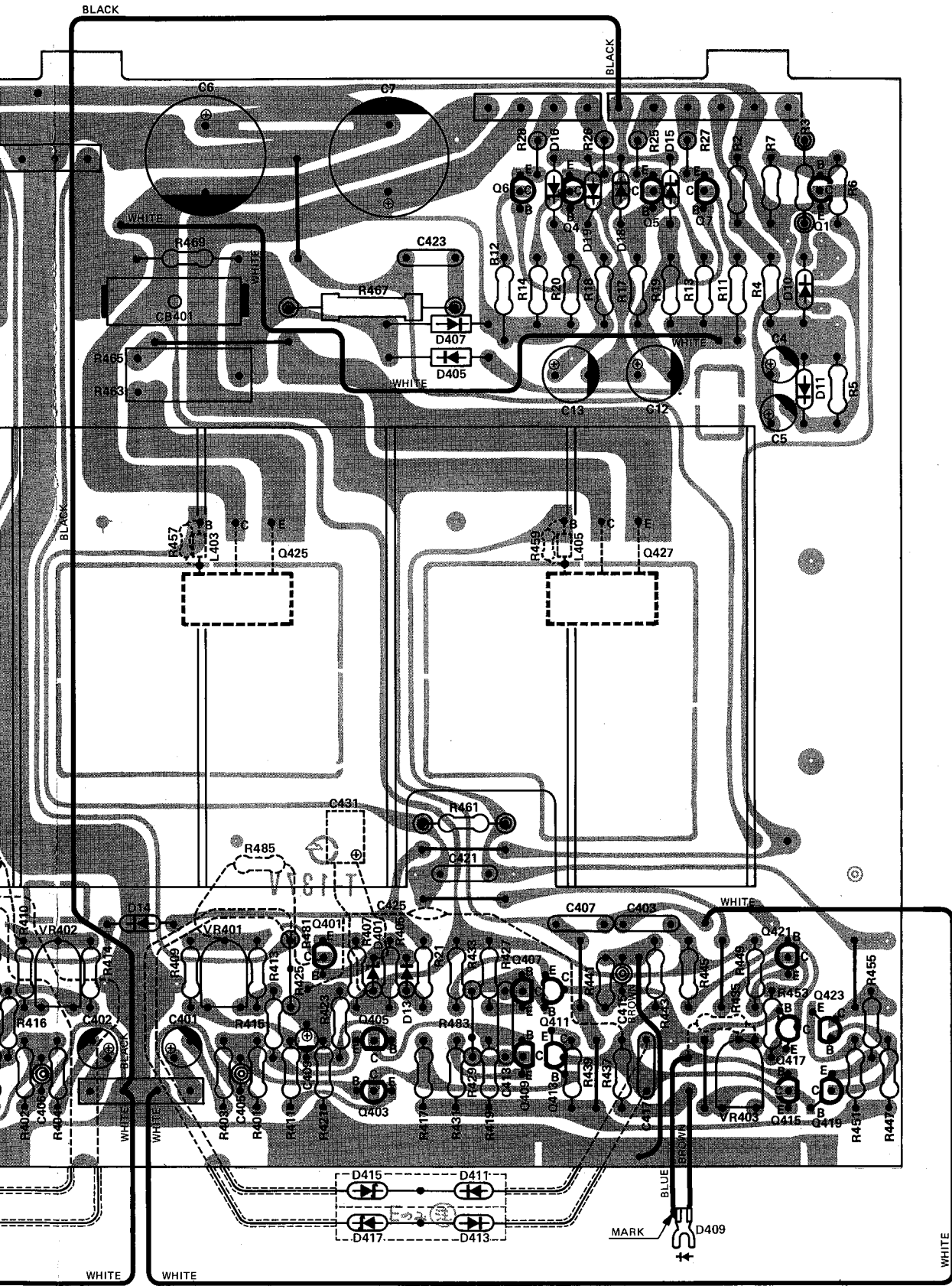

**TAPE SWITCH P.C. BOARD**

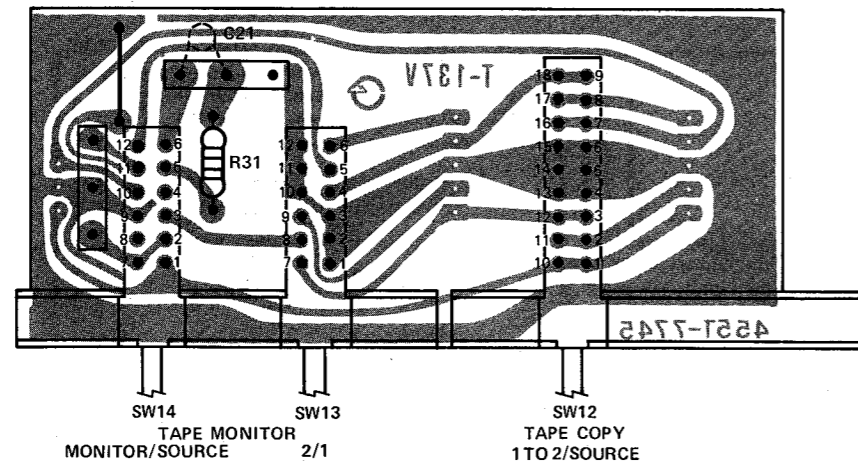

Ref. No.	Part No.	Description
SW12	4431-01068094	Push Switch, Tape Copy
SW13, 14	4431-02087159	Push Switch, Tape Monitor

**SIGNAL STRENGTH DISPLAY P.C. BOARD**

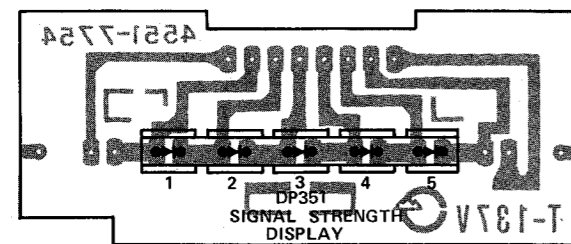

Ref. No.	Part No.	Description
DP351	5637-LN05302P	LED Display Assembly, LN05302P Signal Strength Display

**QUARTZ LOCK/STEREO INDICATOR P.C. BOARD**

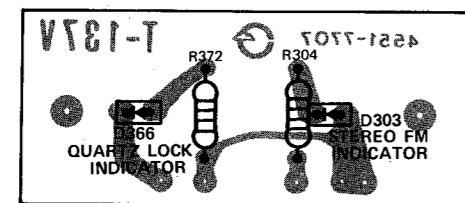

Ref. No.	Part No.	Description
D303	5637-GL9PR20	Light Emitting Diode, GL9PR20 Stereo FM Indicator
D366	5637-GL9NG2	Light Emitting Diode, GL9NG2 Quartz Lock Indicator

**PRESET MEMORY INDICATOR P.C. BOARD**

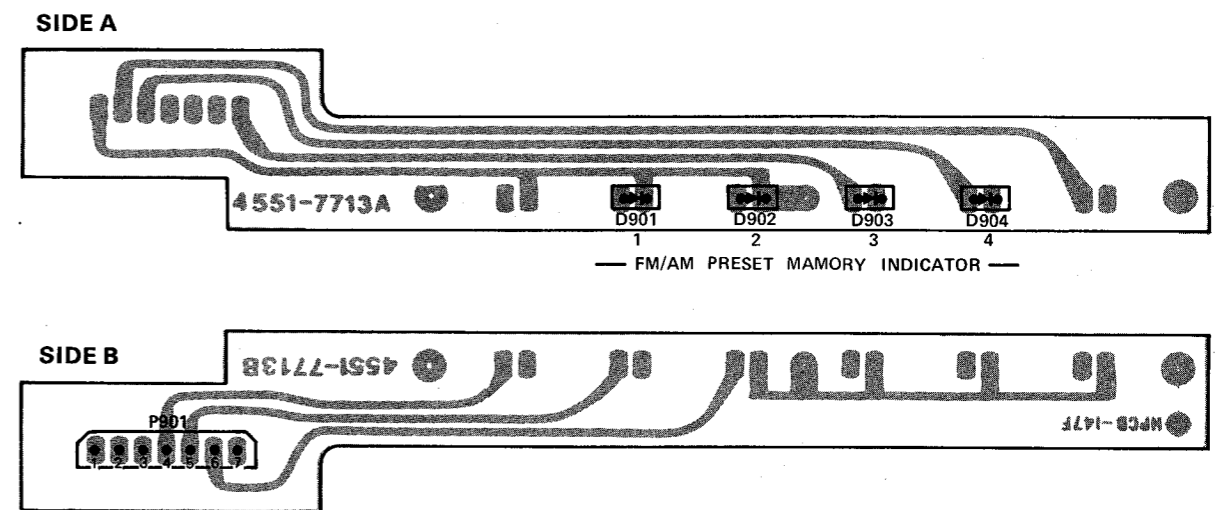

Ref. No.	Part No.	Description
D901, 902, 903, 904	5637-GL9NG2	Light Emitting Diode, GL9NG2 Preset Memory Indicator

**FUNCTION INDICATOR P.C. BOARD**

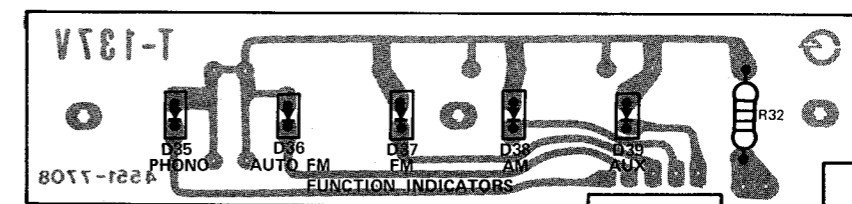

Ref. No.	Part No.	Description
D35, 36, 37, 38, 39	5637-GL9NG2	Light Emitting Diode, GL9NG2 Phono, Auto FM, FM, AM, AUX indicator

**STATION DISPLAY P.C. BOARD**

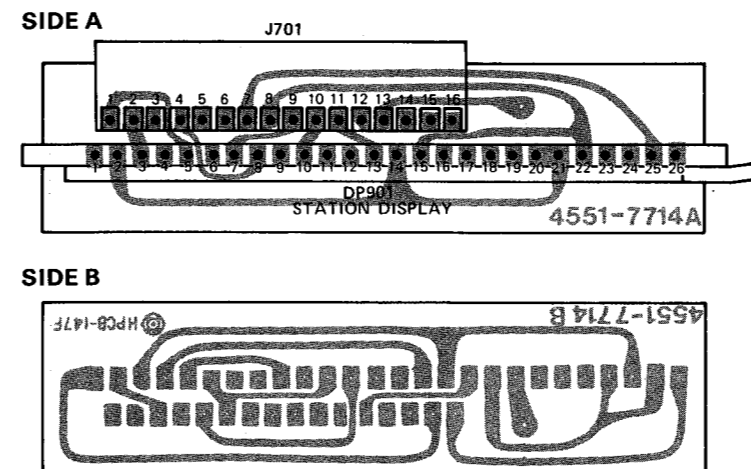

Ref. No.	Part No.	Description
DP901	5722-9	Tube Display Assembly, FIP7D8 Station Display

**SCAN STOP/TUNING SWITCH P.C. BOARD**

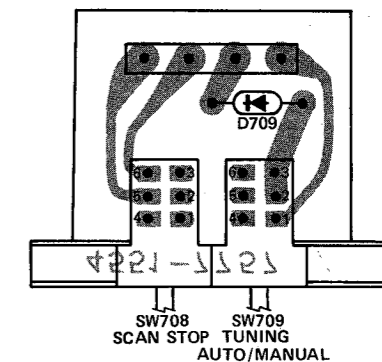

Ref. No.	Part No.	Description
D709	5636-1S2473	Diode, 1S2473
SW708, 709	4431-02047459	Push Switch, Scan Stop, Auto/Manual Tuning

### TAPE SWITCH P.C. BOARD

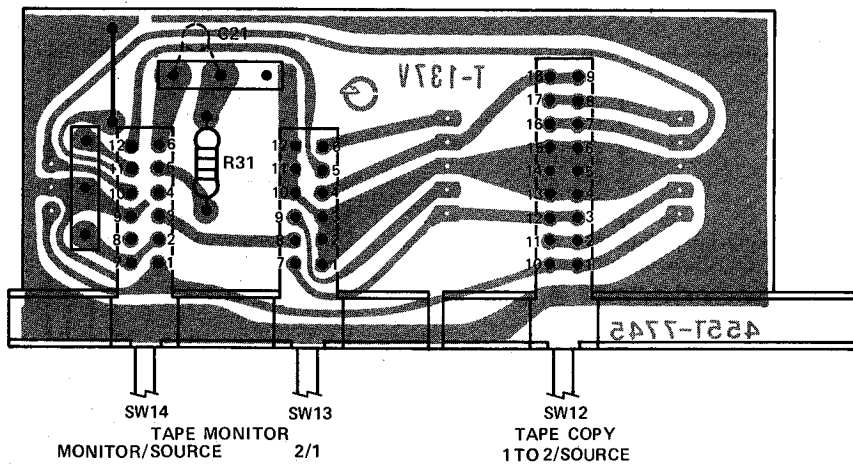

Ref. No.	Part No.	Description
SW12	4431-01068094	Push Switch, Tape Copy
SW13, 14	4431-02087159	Push Switch, Tape Monitor

### SIGNAL STRENGTH DISPLAY P.C. BOARD

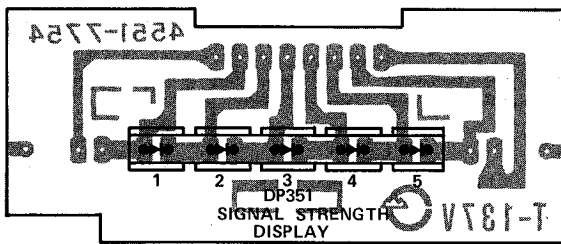

Ref. No.	Part No.	Description
DP351	5637-LN05302P	LED Display Assembly, LN05302P Signal Strength Display

### QUARTZ LOCK/STEREO INDICATOR P.C. BOARD

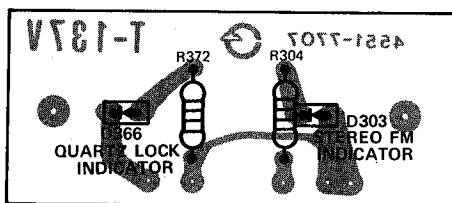

Ref. No.	Part No.	Description
D303	5637-GL9PR20	Light Emitting Diode, GL9PR20 Stereo FM Indicator
D366	5637-GL9NG2	Light Emitting Diode, GL9NG2 Quartz Lock Indicator

### STATION DISPLAY P.C. BOARD

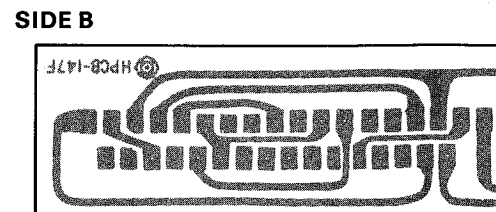
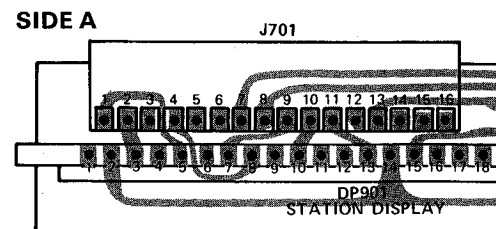

Ref. No.	Part No.	Description
DP901	5722-9	Tube Display

### PRESET MEMORY INDICATOR P.C. BOARD

SIDE A

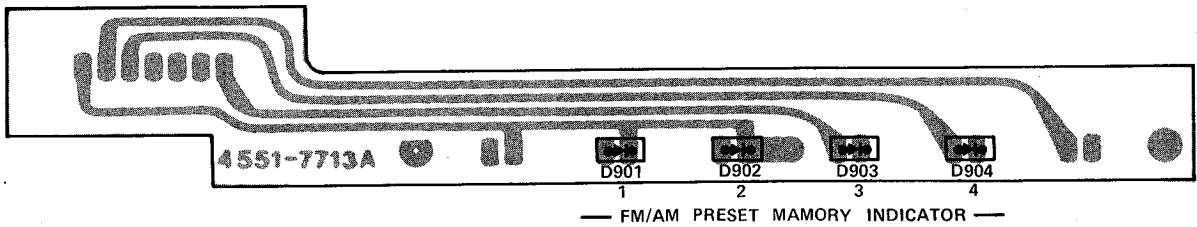

SIDE B

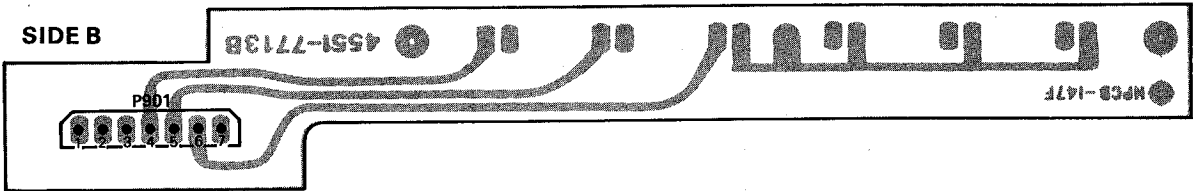

Ref. No.	Part No.	Description
D901, 902, 903, 904	5637-GL9NG2	Light Emitting Diode, GL9NG2 Preset Memory Indicator

### FUNCTION INDICATOR P.C. BOARD

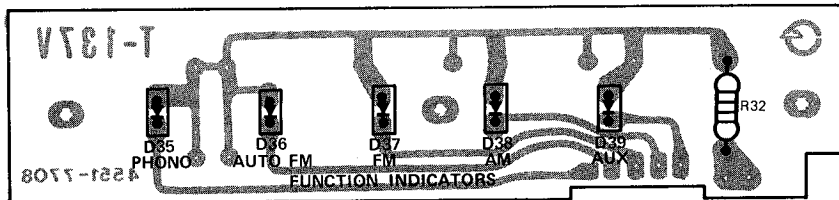

Ref. No.	Part No.	Description
D35, 36, 37, 38, 39	5637-GL9NG2	Light Emitting Diode, GL9NG2 Phono, Auto FM, FM, AM, AUX indicator

### P.C. BOARD

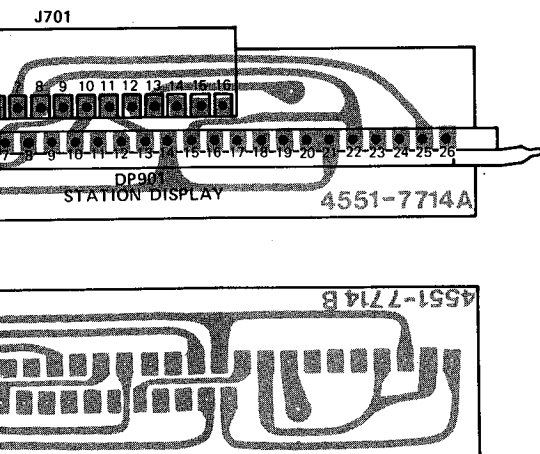

Part No.	Description
722-9	Tube Display Assembly, FIP7D8 Station Display

### SCAN STOP/TUNING SWITCH P.C. BOARD

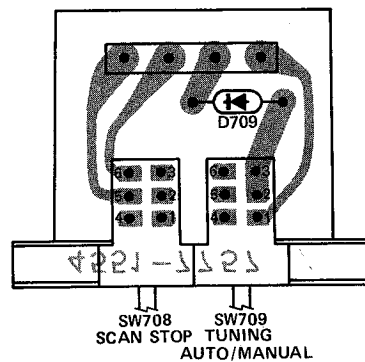

Ref. No.	Part No.	Description
D709	5636-1S2473	Diode, 1S2473
SW708, 709	4431-02047459	Push Switch, Scan Stop, Auto/ Manual Tuning

WIRING DIAGRAM

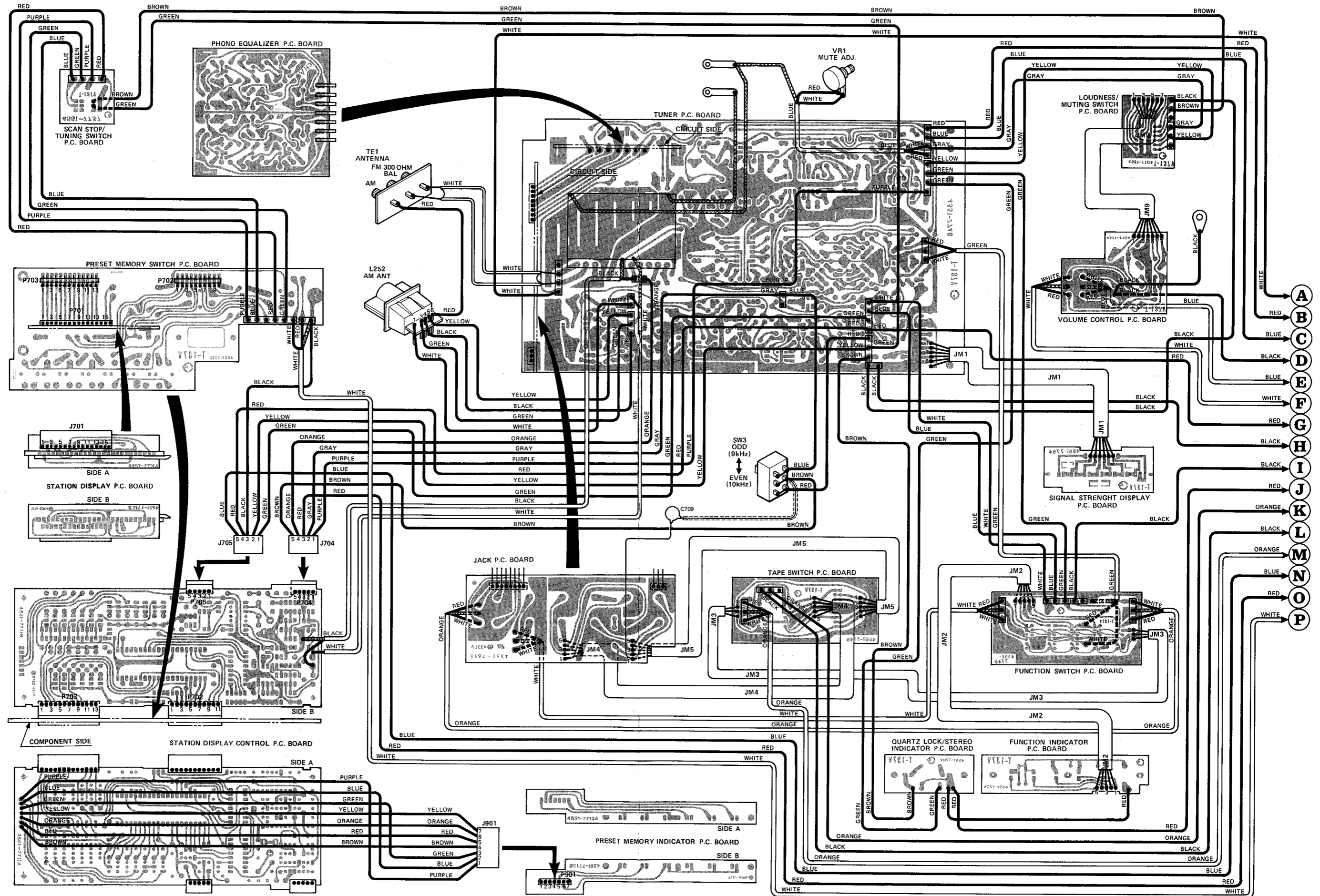



# WIRING DIAGRAM

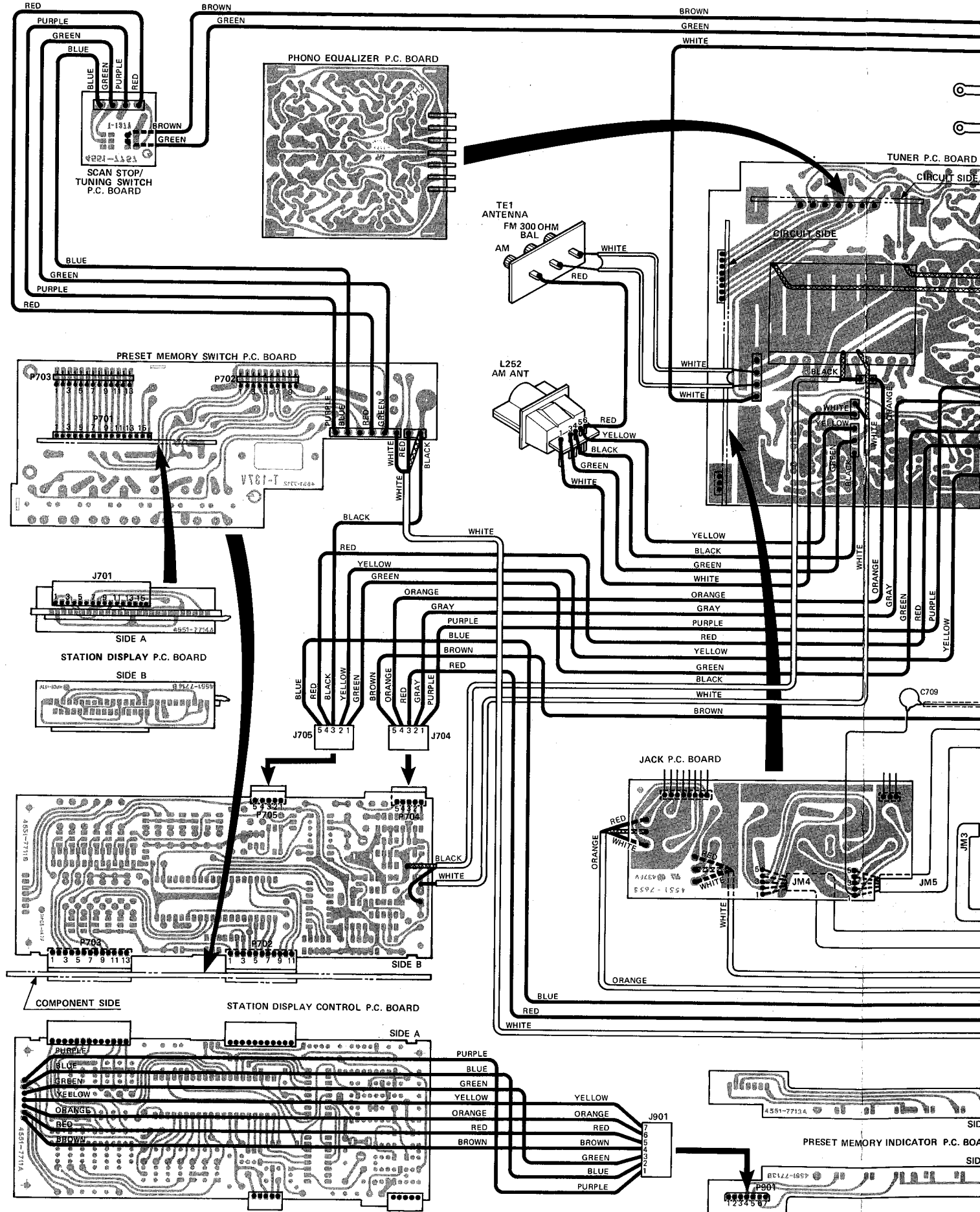

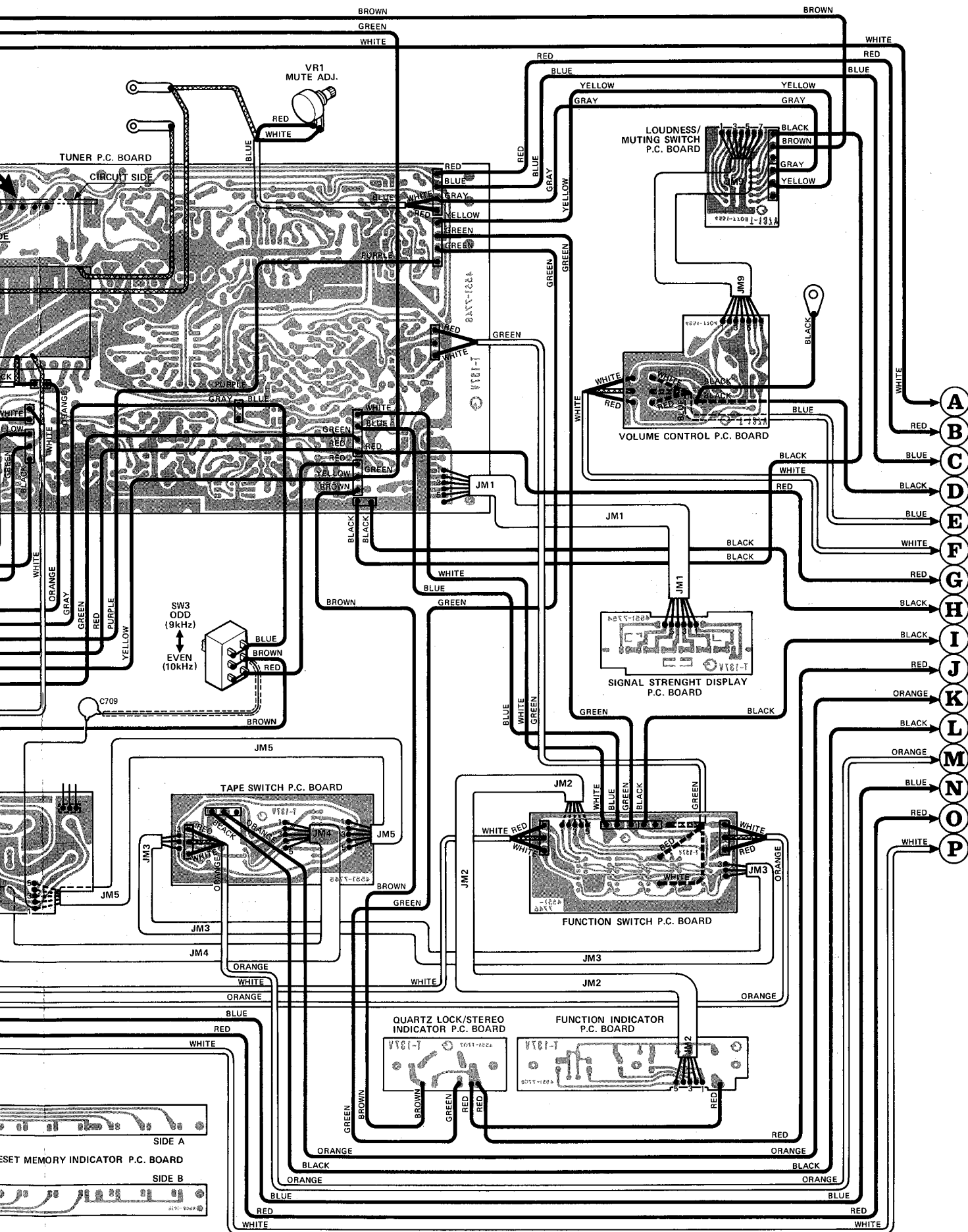

WIRING DIAGRAM

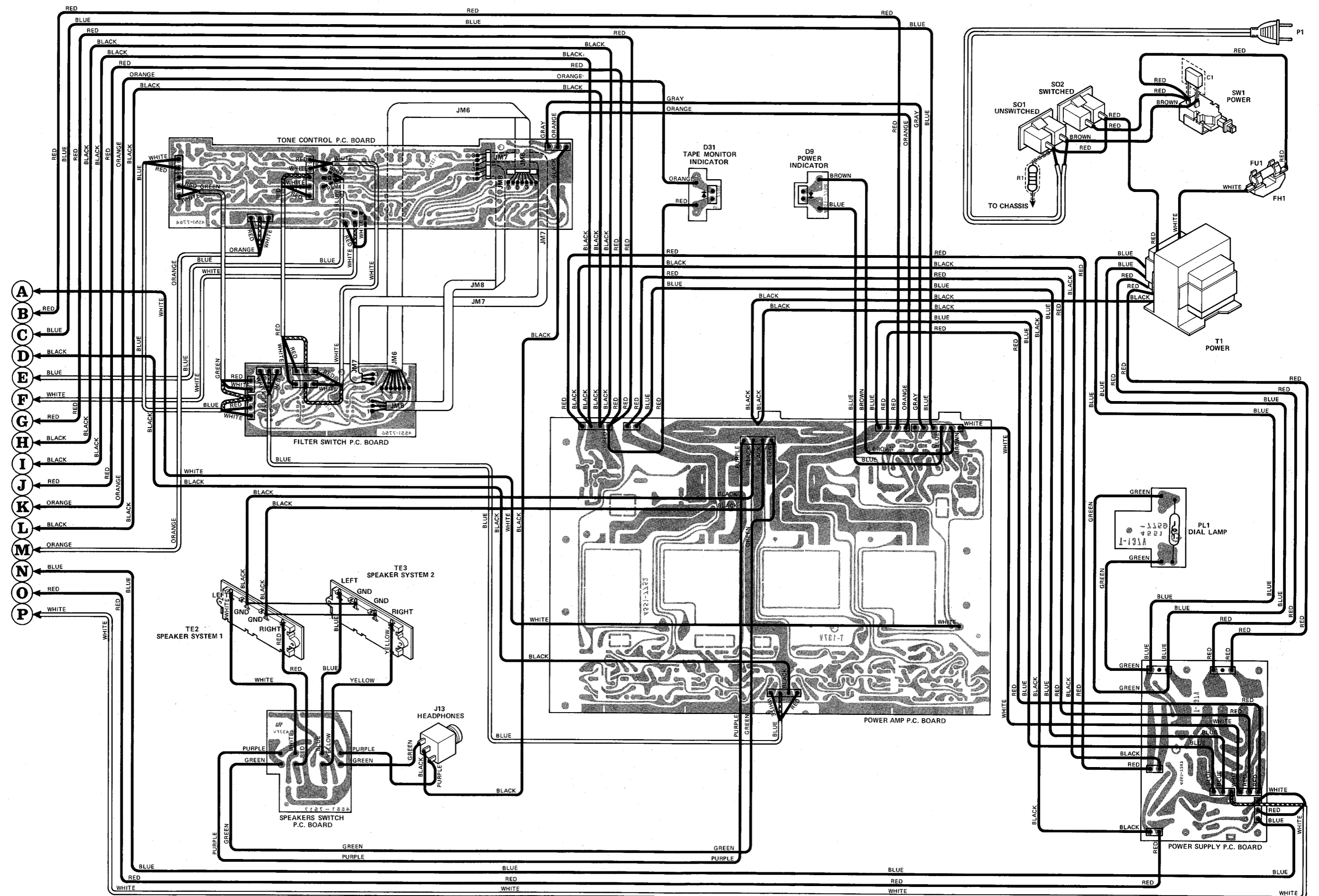

# WIRING DIAGRAM

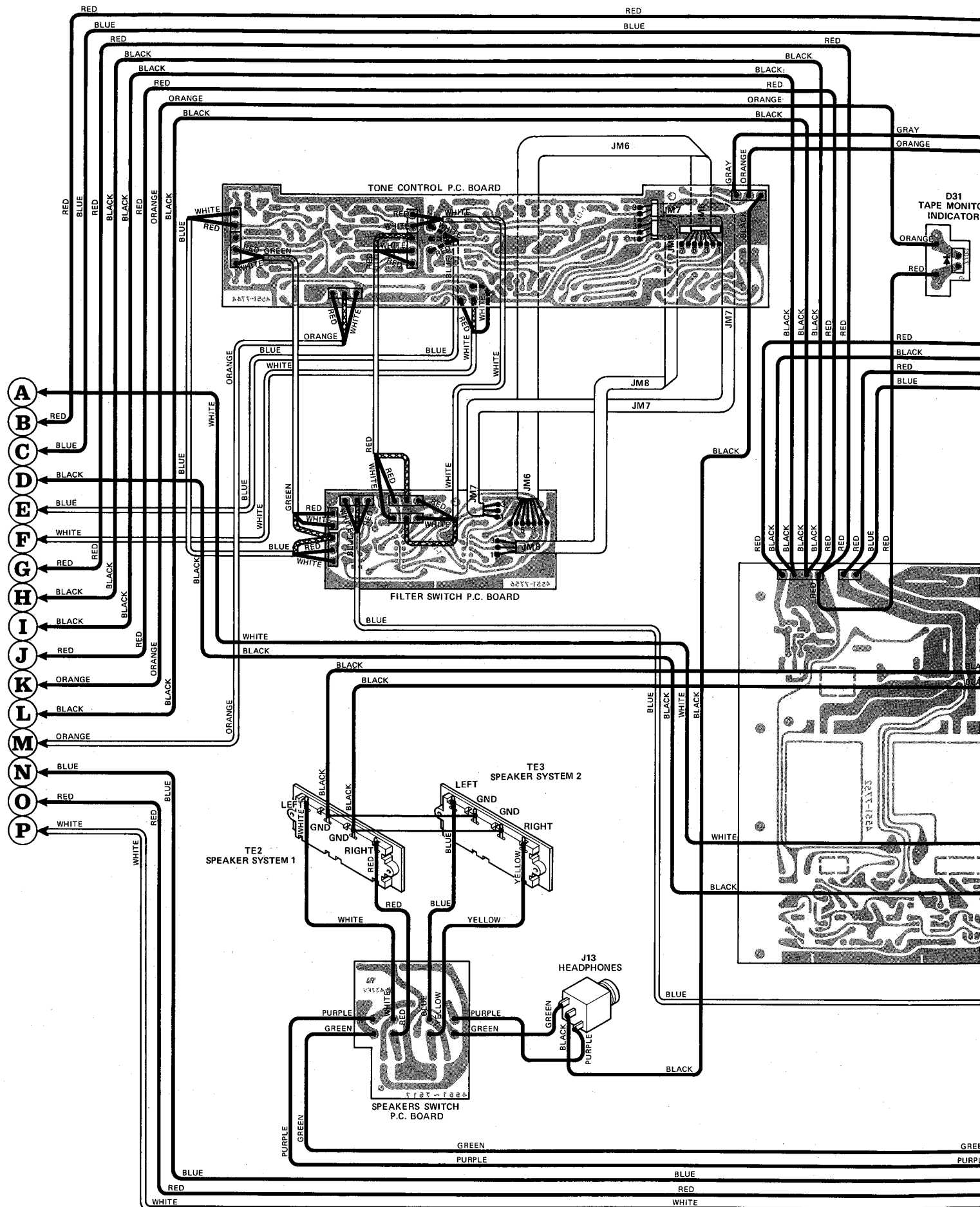

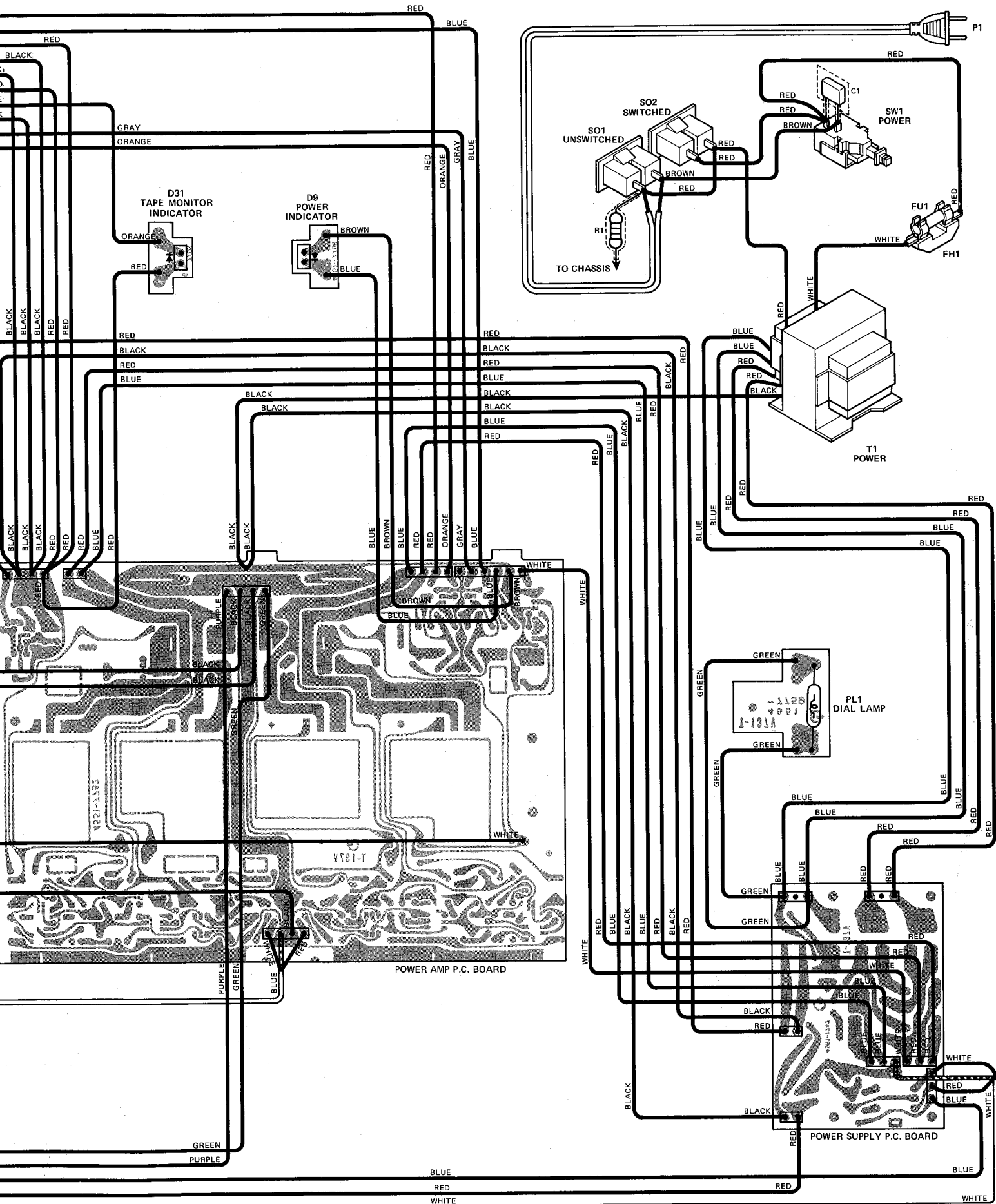

GENERAL UNIT EXPLODED VIEW

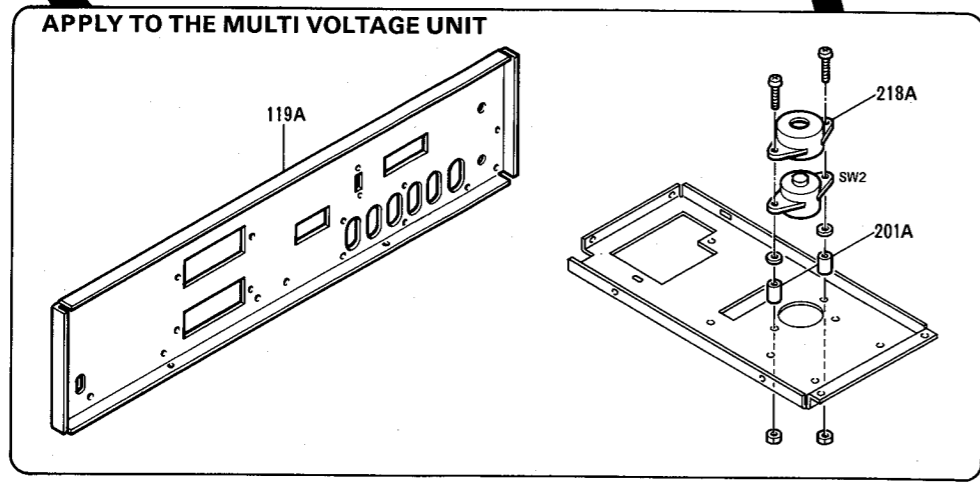
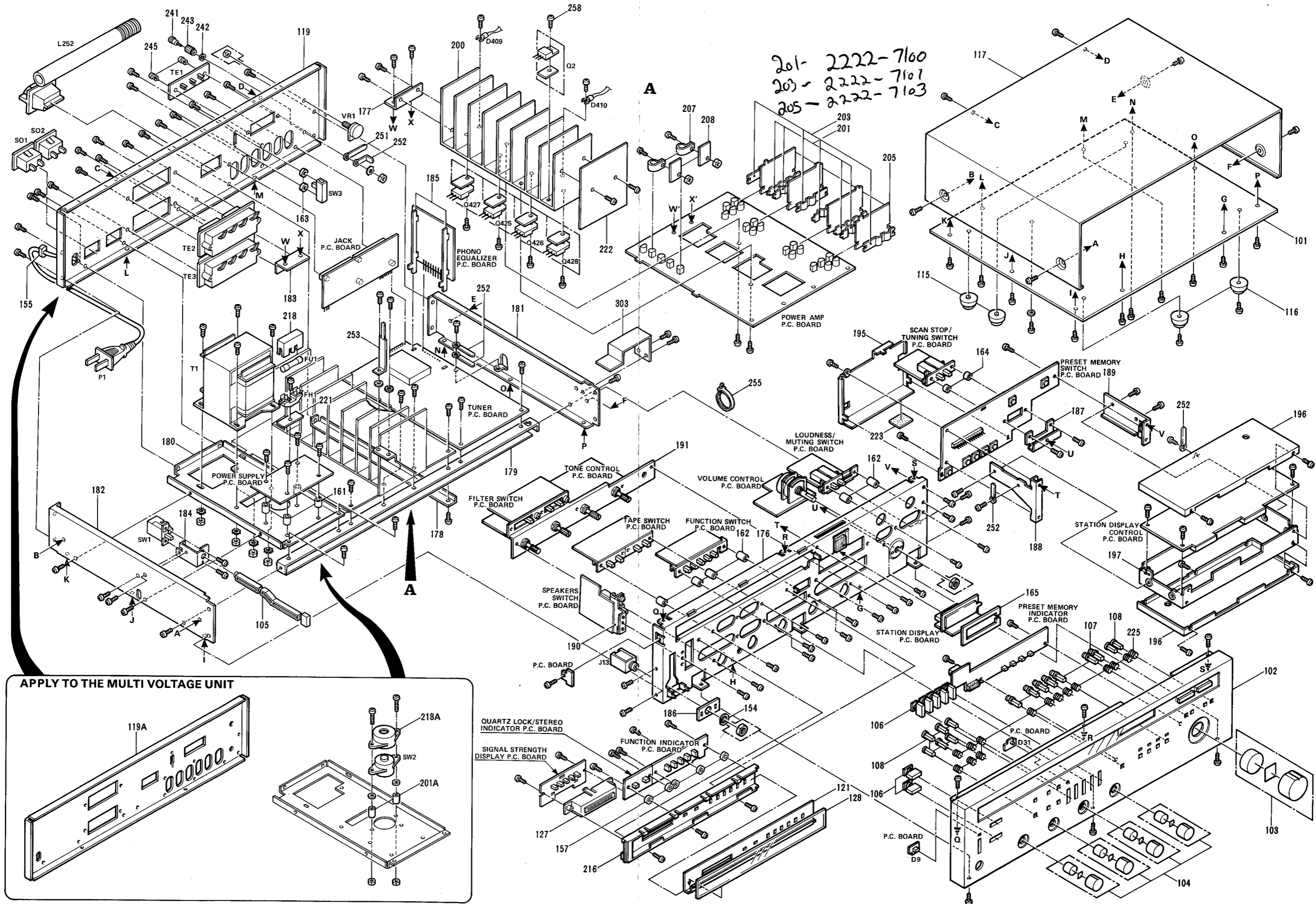

# GENERAL UNIT EXPLODED VIEW

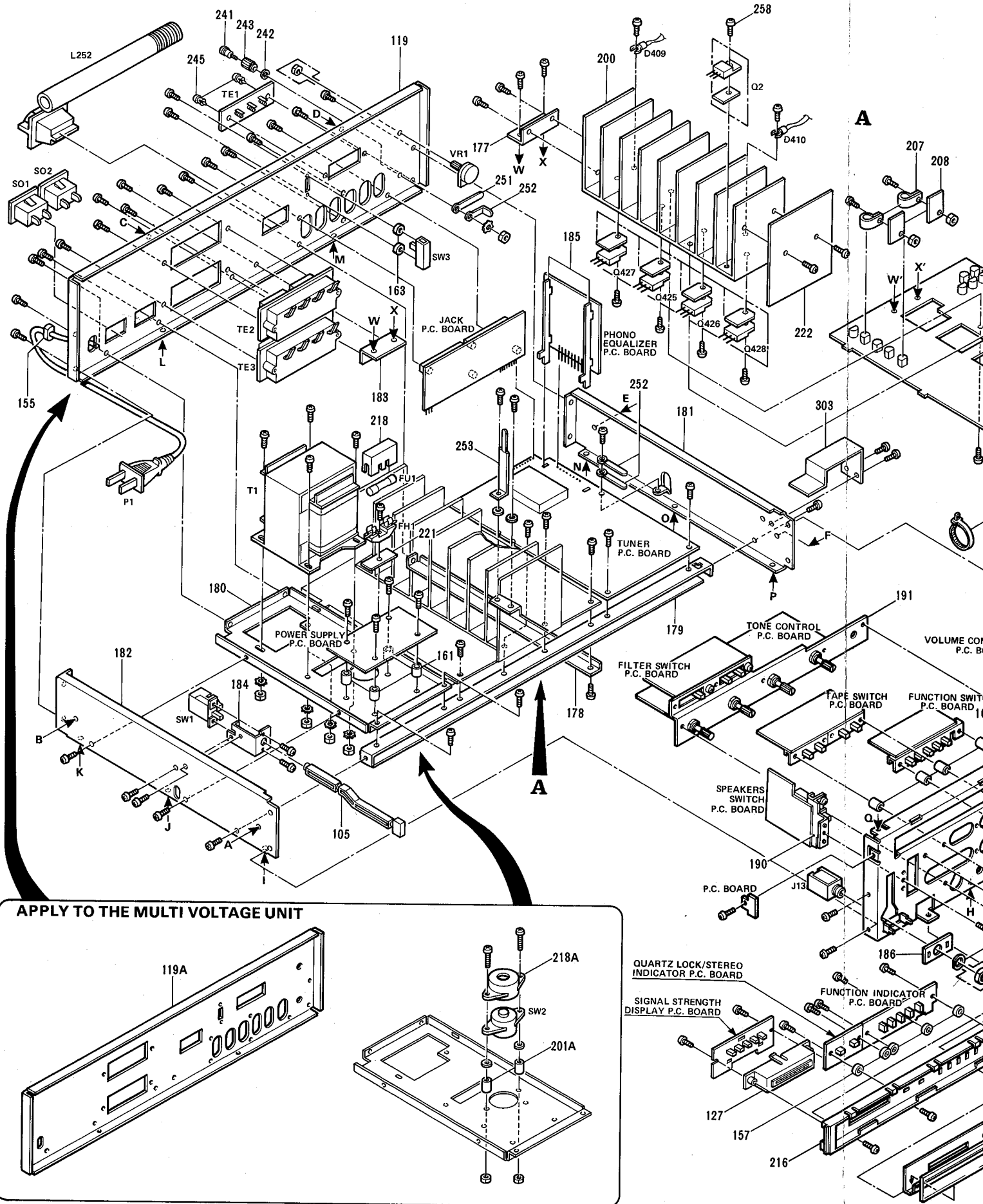

## APPLY TO THE MULTI VOLTAGE UNIT

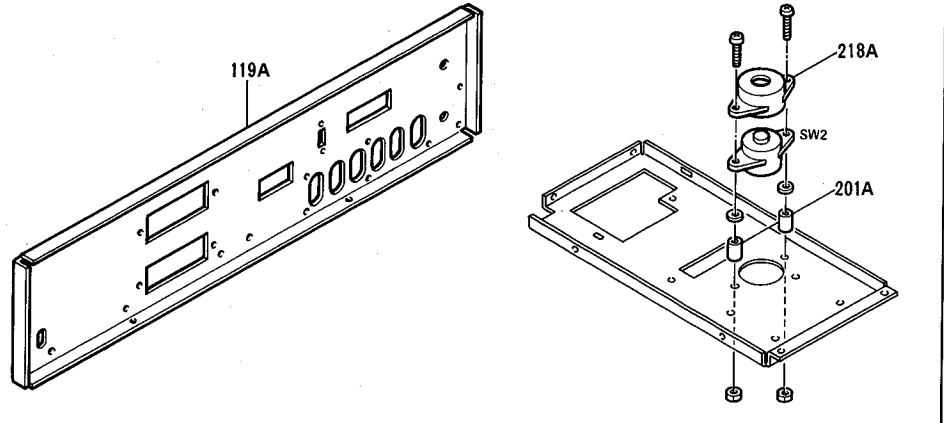

201- 2222-7100  
 203- 2222-7101  
 205- 2222-7103

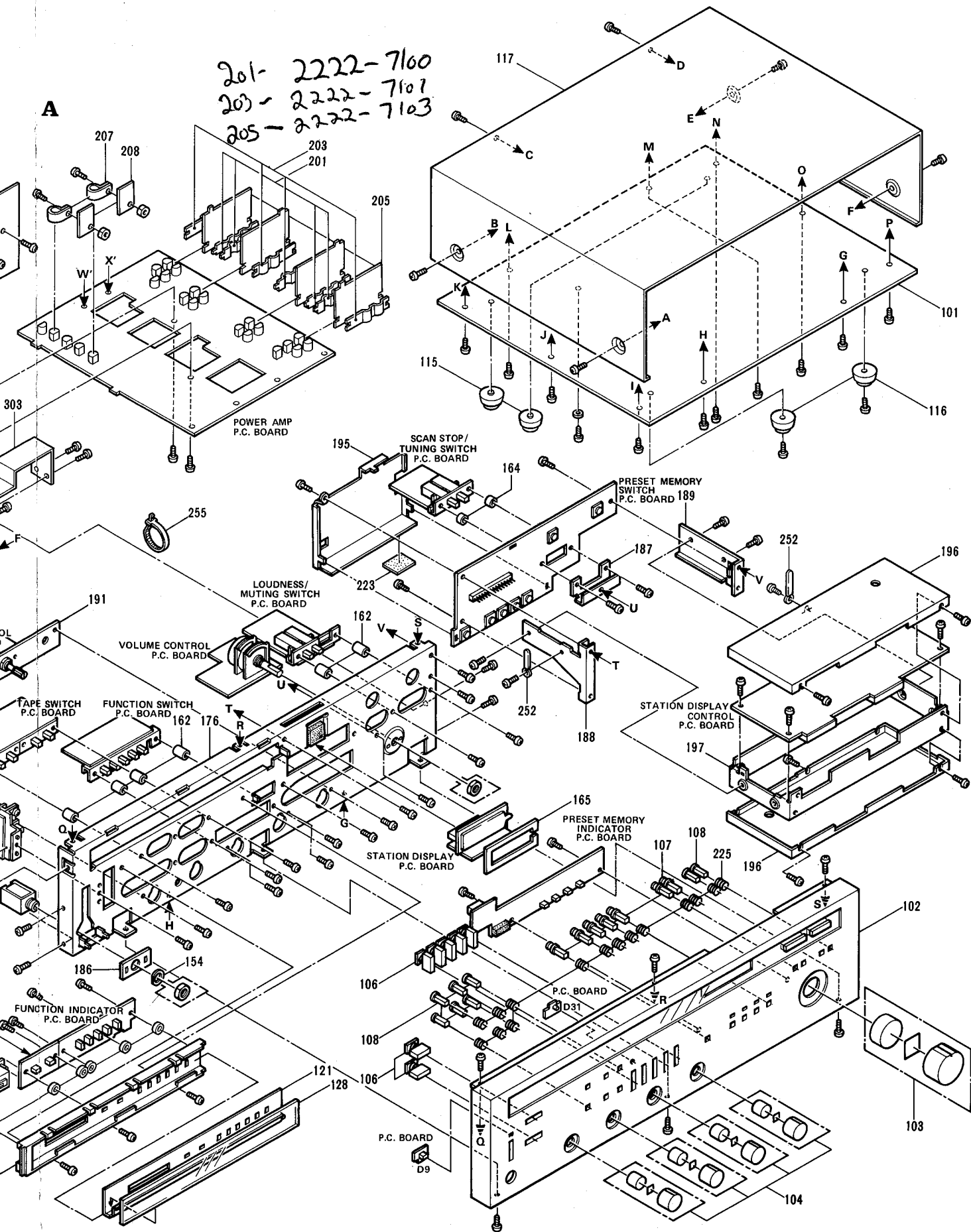



# WIRING DIAGRAM

THE FOLLOWING WIRING DIAGRAM IS APPLIED TO MULTI VOLTAGE UNIT.

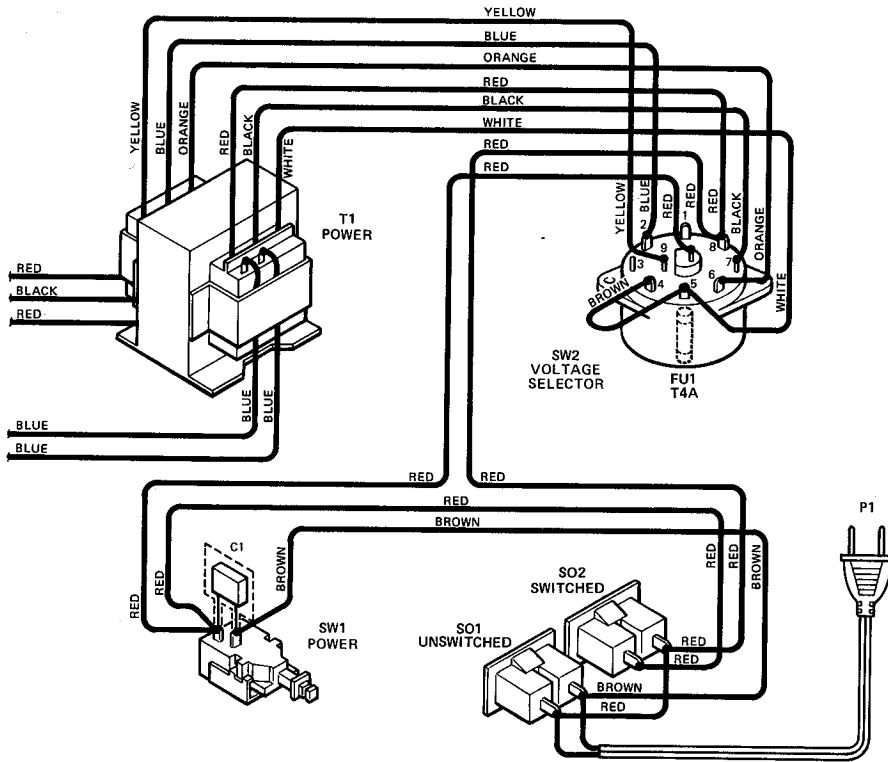

FOR EUROPE AND OCEANIA ONLY

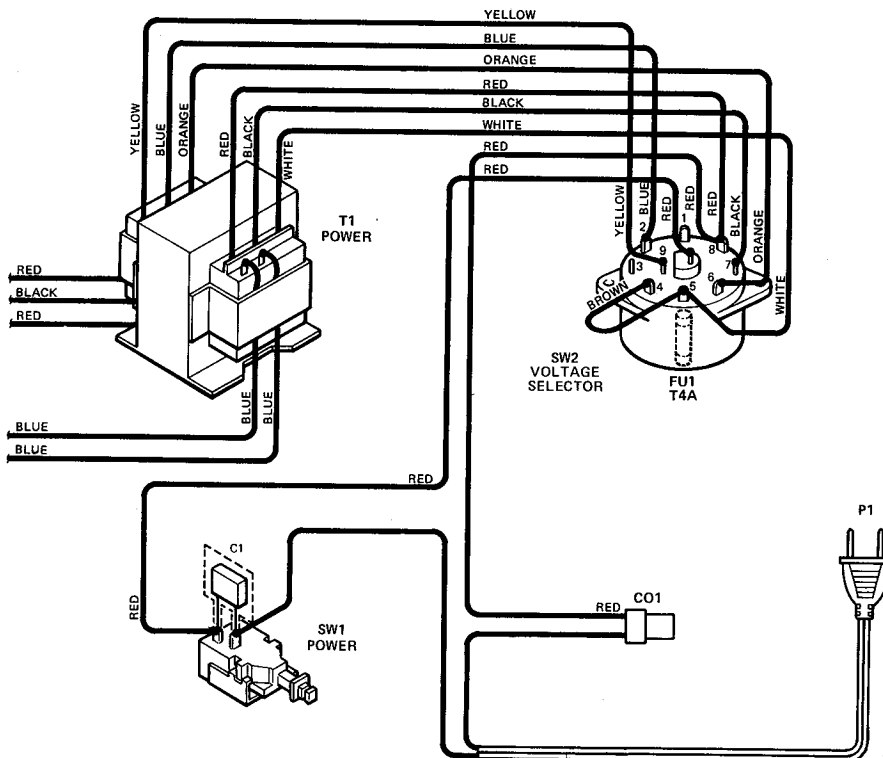

## CHASSIS PARTS LIST

Ref. No.	Part No.	Description
<b>GENERAL UNIT</b>		
101	A423-HK580	Cabinet Bottom Assembly
102	A443-HK580	Front Panel Assembly
103	A634-HK580-A	Knob Assembly, Volume
104	A634-HK580-B	Knob Assembly, Bass, Treble, Balance, Blend
105	A662-HK580-A	Push Button Assembly, Power
106	A662-HK580-B	Push Button Assembly, Speakers 1, Speakers 2, Phono, Auto FM, FM, AM, AUX
107	A662-HK580-C	Push Button Assembly, Memory, FM/AM Preset Memory, Scan Stop, Tuning
108	A662-HK580-D	Push Button Assembly, Tape Copy, Tape Monitor, Tone Defeat, Subsonic Filter, High Cut, Loudness, Muting
115	1319-0139	Foot
116	1319-7138	Foot
117	1414-01101	Cabinet Top
119	1424-04601	Cabinet Back
121	1514-05001	Plate
128	1721-01003	Indication Plate
218	2240-7118	Holder
241	2310-7015	Special Screw
242	2410-7005	Special Washer
243	2440-7011	Special Nut
<b>ELECTRICAL</b>		
P1	4161-7387	AC Line Cord
S01, 2	4474-108	External AC Socket, Unswitched, Switched
SW1	4431-01017358	Push Switch, Power
SW3	4421-0227131	Slide Switch, Frequency Interval Selector
T1	5584-701356	Power Transformer
FU1	5732-402031	Fuse, 4A 125V
FH1	4472-0125	Fuse Holder, FU1
TE1	4214-102	FM/AM External Antenna Terminal
TE2, 3	4214-7034	Speaker Terminal, Speaker System 1, 2
PL1	5731-1507245	Lamp, 15V 100mA Dial Illuminator
VR1	5113-5037221	Variable Resistor, 50 k ohm Muting Adj.
C1	5352-1030959	Capacitor, 0.01 uF $\pm$ 20% AC125V Metalized Polyester
D9	5637-GL9PR20	Light Emitting Diode, GL9PR20 Power Indicator
D31	5637-TLR206	Light Emitting Diode, TLR206 Tape Monitor Indicator
L252	5911-208	AM Ferrite Loopstick Antenna
J13	4451-00108	Jack, Headphones
	1397-6	Dipole Antenna

## MULTI VOLTAGE VERSION PARTS LIST

AS FOR ALL OTHER PARTS EXCEPT THE FOLLOWING PARTS IN REF. NO., REFER TO REGULAR VOLTAGE UNIT (120V ONLY).

Ref. No.	Part No.	Description
<b>PART NO. CHANGE</b>		
119	1424-04602	Cabinet Back
119A	1424-05601	Cabinet Back (for Europe and Oceania only, (SK) (SEV))
P1	4161-7256	AC Line Cord
SW1	4431-01017658	Push Switch, Power
T1	5584-701311	Power Transformer
FU1	5732-402030	Fuse, T4A 250V
FU2, 3, 4, 5	5732-312030	Fuse, T3.15A 250V
FU6	5732-631030	Fuse, T630mA 250V
IC201	5652-HA12412	Integrated Circuit, HA12412 FM IF Amp./FM Det.
R429, 430	5102-1524713	Resistor, 1.5 k ohm $\pm 2\%$ 1/4W Fuse
C1	5352-1030961	Capacitor, 0.01uF $\pm 20\%$ AC250V Metalized Polyester
C1	5352-1030958	Capacitor, 0.01uF $\pm 20\%$ AC250V Metalized Polyester (for Sweden only, (SEV))
<b>ADDITIONAL USAGE</b>		
SW2	4467-1	Power Source Voltage Selector
SW4	4421-022110	Slide Switch, De-Emphasis
CO1	4443-712	Connector, AC Line Cord (for Europe and Oceania only, (SK) (SEV))